



INTERNATIONAL SNOWMOBILE RACING

1527 North Railroad Street Eagle River, WI 54521

262-335-2401

SPEED RUN 2023-24

VERIFICATION AND CONTROL

These GENERAL RULES apply to all types of ISR racing sanctions and all classes unless so noted. All participants, racers and crewmembers are required to be fully aware of these regulations and must abide by them.

The rules for competition are intended only as a guide for the conduct of the sport in a uniform manner from region to region.

Safety rules and guidelines contained herein are of utmost importance. All participants must be concerned with safety and be familiar with these rules and guidelines. However, ISR does not warrant, guarantee, or ensure safety even if the rules are enforced and/or adhered to. Moreover, each participant in competition has the responsibility to assess the safety aspects of the facilities and conditions and must assume the risk of competition.

MANDATORY EMERGENCY VEHICLE

1. A properly licensed and equipped emergency vehicle (i.e., rescue vehicle or ambulance) must be at the race site to transport injured persons to an appropriate hospital. This vehicle shall have all emergency equipment. Contract arrangements must be made to have a transport situation ambulance on site if a transport is made. Many tracks are now using a track owned ambulance for on-site work. Many times, these vehicles are not certified for transport of patients on the highway. Arrangements must be made for a certified transport ambulance to make the actual patient transport. Racing must not be allowed without an ambulance on the grounds.
2. If an event is located at a ski hill facility and it has qualified ski patrol personnel (Paramedics - ALS) and an onsite room fully equipped as an ambulance would be it can be substituted for the actual vehicle. When The terrain and driving distance by ambulance makes it advantages to use a prearranged air ambulance this method can be used to transport injured persons to an appropriate hospital after stabilization by Ski Patrol personnel. (Paramedics - ALS)

RULE SUPPLEMENTS

1. Rule supplements, additions or corrections shall be announced on the official website. Upon such an announcement the rule changes become effective and enforceable.
2. Telephonic race rules conference calls will be followed up with an information letter to the affected affiliates.
3. After a rules meeting, any request to reconsider a new rule requires a majority vote of the rules committee to approve a revote. Then, a $\frac{2}{3}$ majority is also required to change the rule.

CLASS DIVISIONS

1. All class entries will not discriminate based on sex. Any qualified member may participate in the approved classes offered in any sanctioned event.
2. A snowmobile will be allowed to race in its respective displacement, or designated performance class, and any larger displacement or performance class, except as noted in specific sections.

REGISTRATION AND ENTRY

1. **WAIVER FORMS ARE MANDATORY FOR ALL PERSONNEL IN SECURED AREAS (paddock, staging and track).**
2. Driver must have registered at race headquarters and signed a waiver before any runs are made (practice or racing). No one, except officially entered drivers may ride or practice on any racecourse on the day of the event.
3. No refunds of entry or other fees will be made at sanctioned events after registration is closed, unless the event is cancelled or rescheduled by a ruling of the Race Director, after which time fees will be returned or advanced to the next event in the series.
4. Any competitor who pays for race entry or organization membership with a check or credit card is responsible for the payment of all charges should the bank or other institution fail to remit for whatever reason.
5. Drivers who fail to complete payment for entry fees are subject to discipline prescribed by the ISR affiliate. Drivers may be suspended for a period of one year from the date on which the debt is paid.
 - a. If the participant stops payment on check or credit card, participant gives up the right to protest or appeal until full payment is made.

- b. Participants who pass NSF checks must pay entry and prescribed fees in full before the next race or within 30 days, whichever is sooner.
6. Insurance fees are not refundable.
7. Regional service charges or insurance surcharges are not considered part of entry fee maximums.
8. Gate admission fees for driver and crewmembers will be regulated on a regional basis.
9. The order of events will be regulated on a regional basis.
10. The maximum number of classes a driver can enter per day will be regulated on a regional basis.
11. Any class or event can be eliminated when there are less than two (2) official entries at the close of registration.
12. All participants in events must be fully familiar with the rules and regulations, plus such rules by Race Promoters that may be specifically applied to any event.

DRIVER AND SNOWMOBILE

1. A driver and his snowmobile (chassis and engine) shall be considered a unit and once the class has begun, neither will be substituted. If a driver qualified on a snowmobile, both must be in the same final event of the class and/or event.
2. Engine parts may be replaced during the event, except for the crankcase and crankshaft, which may not be replaced.

SPONSOR IDENTIFICATION

1. Anytime the sanctioning organization or sanctioned event has a sponsorship, all members and promoters must meet sponsorship requirements, if drivers' number system is not compromised.
2. Recommended size for any sponsor's required emblem should not exceed sixteen (16) square inches on the front and twenty-four (24) square inches on the back of the driver's uniform.

DRIVER IDENTIFICATION

1. There will be an automatic suspension for drivers who race under another driver's number.
2. All drivers will wear their issued bib or a facsimile thereof. Drivers will be required to keep the snowmobile numbers and drivers' body back numbers in a legible condition. Drivers must either wear a bib with their number for the event or their number built into the upper body outer garment worn during competition. Numbers are to be 8 inches high with a one- inch width.

SNOWMOBILE IDENTIFICATION

1. Snowmobiles will have the appropriate number plate affixed to their race vehicle. Regional and affiliate rules may require background colors and contracting numbers for each class. ISR supports this requirement.

PRE-RACE SAFETY INSPECTION

1. ANY ENTRY IS SUBJECT TO INSPECTION AT ANY TIME UPON REQUEST BY THE RACE DIRECTOR OR TECHNICAL DIRECTOR.
2. Pre-race safety inspections are mandatory at all races. Passing a pre-race safety inspection is no guarantee that a snowmobile complies with all rules for the event. Affiliates may allow prerace safety inspections to be conducted at the first race of a series and allow the sled to compete in subsequent events in the series without reinspection if on track records indicate no evidence crashes during competition.
3. Only snowmobiles having passed pre-race inspection will be allowed on the racetrack.
4. All aspects of modification are contingent on safety inspection by the Technical Director. The Technical Director may remove any snowmobile from competition that does not meet safety requirements.
5. Damaged or broken safety equipment (not including tether switch) not detected during a race is not grounds for disqualification after completion of that race unless black-flagged during the race in question.

MANDATORY TEARDOWN

1. Regardless of snowmobile equipment passing prior inspections, compliance with the rules must be made at the post-race inspection.
2. Once a snowmobile has completed registration to race it may be inspected at any time.
3. Tech Director will select the snowmobiles for mandatory teardown and inspection. Drivers will take their snowmobiles directly to Tech after completing the race. The Tech Director may indicate the area or trailer he wishes the sled to be disassembled in. The snowmobile must remain in Tech until released by the Tech Director or a designated member of the Tech staff.
4. Driver and/or driver's mechanic will perform teardown to point required by the Technical Director.
5. Any driver not reporting to Tech or refusing teardown will be disqualified.
6. Inspected snowmobiles will not be reassembled by the inspection group.
7. Driver and/or driver's mechanic will be the only people allowed in the inspection area.
8. The sanctioning organization assumes no responsibility for impounded snowmobiles.

SEALS

1. Drivers will allow the installation of a seal or seals on the engine and/or body of their racing snowmobiles. To change the seal, mutilate it or try to break it, or re-use it, during the weekend or event where it is installed without the consent of the Race Director, could result in the responsible driver being called before the disciplinary committee for strict discipline. Accidental breakage of the seal must be reported to the Race Director immediately.

PROTESTS

1. All formal protests must be made in writing, by a driver, in competition at the event, from the class in question, on a formal protest form, accompanied by a cash protest fee (protest fee may vary by region or circuit) two hundred and fifty dollars (**\$250.00**) recommended.
2. When the official protest is made with the fee, the item to be protested must be stated (a general protest will not be accepted), teardown will not be complete until protest is found to be valid or proven unwarranted. If the protest is valid, the fee will be returned to the protester. If the protest is invalid, the fee will be given to the protested snowmobile owner for the inconvenience (to be accomplished before the snowmobiles are released from teardown). Affiliates may set an increased fee for a total tear down process in which all areas are inspected. Affiliates have the right to refuse nuisance tear down protests generated by individual personal relationships, or on track activity. This fee may be given to the affiliate, or a charity named by the affiliate.
3. There is no need for formal protests in the case of driving infractions during an event. Reports of such alleged infractions should be made to the Race Director, who in turn will request a report from the flagman or assigned official on the course.
4. Race Director has the authority to determine the validity of a protest.
5. No protests will be accepted that refer to a Race/Technical Director's judgement or decision.
6. It shall not be possible to protest or appeal technical inspection equipment, manual /electronic scoring, or manual/electronic timing equipment.
7. Protests must be filed within thirty (30) minutes following the completion of the daily event or within thirty minutes following the official announcement of results for the class in question whichever occurs first. Race directors have the authority to increase the time to file a protest for a competitor but may not shorten the time allowed.
8. Properly filed protests must be addressed by sanctioning body before finalizing class results. ISR must be informed of the protest in writing immediately after the protest is filed. Electronic method of communication preferred.

APPEALS PROCESS

The following appeals process shall be applicable for all ISR affiliates and will be the binding operational guide and procedure statement for all affiliates. For any Affiliate that has an internal Appeals Process, the process will only apply to operations inside the association or company and will not have any bearing on race rule interpretation, infractions, misconduct, or other situations that may arise from race activity.

TECHNICAL INFRACTIONS

Driver or team are found in non-compliance with the rules concerning fuel, sled construction, specific dimensions, materials used, or components used not conforming to the rules for each specific class, the following will be the procedure.

Tech Director or Race Director determines infraction and makes the appropriate decision considering the gravity of the offence. The Director may:

- a. Verbally warn driver or team.
- b. Disqualify driver from event for the class specified.
- c. Disqualify driver from all events entered in days competition.
- d. Fine driver, if affiliate has a fine process in place in the affiliates bylaws or published operational guide, and the fine system is published in their membership documents.
- e. Suspend driver or team for season.

ON TRACK INFRACTIONS

Race Director determines infraction and makes the appropriate decision considering the gravity of the offence. The Director may:

- a. Verbally warn driver or team.
- b. Disqualify driver from event for the class specified.
- c. Disqualify driver from all events entered in days competition.
- d. Fine driver, if affiliate has a fine process in place in the affiliates bylaws or published operational guide, and the fine system is published in their membership documents.
- e. Suspend driver or team for season.

If the affected driver feels the decision is not correct, he/she may appeal the decision in the following manner.

1. The Appeal must be presented to the affiliate Race Director in writing using the ISR approved form available from the ISR web site. This form must be presented within 30 minutes of the announcement of the disqualification or penalty. Race directors have the authority to increase the time to file a protest for a competitor but may not shorten the time allowed. The Appeal must be accepted by the affiliate.
 2. The affiliate must within 24 hours convene a meeting of the owner/ management/ officials of the affiliate and review the offense/ infraction. If the offense is upheld, the driver/team can request a further appeal to ISR and ask for a review by the rules group for the discipline. ISR has 5 days to conduct such review with the rules committee of the specific discipline.
- If the Appeal is found valid, all points, money, prizes, etc. are returned/ awarded to the driver/team.

3. If the offense is upheld, the Affiliate and the Driver/team must inform ISR of the situation within 24 hours of the alleged infraction. ISR will then, within 5 working days conduct a review of the situation, convene the appropriate rule review group from the proper discipline/aspect and render a decision. The decision of this session is binding and has no further appeal.

Affiliates and Drivers must review the Chain of Custody and submission of components/ fuels/ design concepts presented for the Appeal. If the driver/team does not submit samples, exhibits, photos, etc. of the offending component or fuel, the appeal is considered void, and the penalty stands. If the Affiliate does not accept and submit samples, exhibits, photos, etc. of the offending component or fuel, the appeal is considered void, and the penalty is rescinded, and all prize money, awards and points are returned to the driver/team. There is no appeal of any type to this operational chain of evidence and procedure. The Operational Guideline and Appeals Forms are found here:

[Download Appeal Forms Here](#)

Race Operation Infractions [Click here](#) Rules Interpretation Issues [Click here](#) Business Operation Misconduct [Click here](#)

NOTICE

Driver infractions/ disqualifications in a drag racing, oval racing, Enduro racing, cross country racing, water cross racing, and speed run racing events will be forwarded to all ISR affiliates.

NOTICE

Drivers, promoters, or any personnel affiliated with ISR snowmobile events who are banned from racing or subject to other major penalties by one affiliate, having completed the hearing process, the decision shall be honored by all ISR affiliates in that discipline.

PRIZES AND AWARDS

1. All prizes, awards and paybacks shall be presented to the official winners or their appointed representatives at the close of the event, unless specifically advertised otherwise as to the time and place of awards.
2. Drivers will not be required to attend award banquets, parties, ceremonies, etc., to receive prizes, awards, or pay-backs, although they are encouraged to cooperate as a courtesy to the promoter.

PIT AND PADDOCK/STAGING AREA

1. Reasonable speeds will be observed in the pit and paddock area. All pit areas are caution zones where utmost in driver awareness is required.
2. Hot pit and staging areas are limited to drivers preparing to race and their pit crewmembers. Minimum age for pit crewmembers in these areas is 14 years old. All persons in these areas must have signed a release and waiver for the event.
3. There is no minimum age for people in paddock, pit parking and cold pit areas. It is recommended that people in these areas be required to sign a release and waiver.

TESTING, TUNE-UP, WARM-UP & PRACTICE

1. Testing of the engine and/or snowmobile must be done in a designated area only. Driver must consult with Race Director to determine proper testing areas at each event.
2. Testing area must be a suitable course or area, completely free of obstructions, which provides adequate and safe run-off areas, so competitor may slow down and exit safely.
3. Fences or squared off banks shall not be permitted at the end of the testing area.
4. Officials must provide proper supervision of the testing areas as well as adequate crowd control to prevent spectators or other persons from moving onto the area.

SUPPORT VEHICLES

1. No unauthorized motorized vehicles will be allowed in the pit or staging area. Snowmobiles must return under their own power. Only disabled snowmobiles may be towed from the track.

TEMPORARY SHELTERS

1. Competitors shall not utilize temporary shelters such as tents, sunshades or other structures made from flammable materials. Such equipment shall have proof of flame resistance testing affixed for inspection by race officials.

ANIMALS

1. No aggressive animals will be allowed at the race site.

DRIVER PROTECTIVE EQUIPMENT

It is the responsibility of the racer to select protective equipment that will conform to ISR guidelines and provide adequate protection. Even though race rules committees and ISR develop guidelines, ISR does not endorse or guarantee specific products or manufacturers of protective equipment. Racers must rely on their own judgment in the selection of helmets and other apparel for protection and durability.

1. Regardless of driver apparel passing prior inspections, compliance with the rules must be made at post-race inspections.
2. No cameras or digital acquisition devices can be attached to any driver's helmet. This will be in effect anytime a race vehicle is on the track, whether it be a test, practice session, or in competition.
3. Full coverage helmets are mandatory. Helmets will be full protective coverage and carry the **2020** Snell Foundation Approval Code. Helmets carrying European Standard ECE 22.05 are also approved. This is also mandatory in the tune-up area. The helmet must be securely fastened at all times. Helmet must display original ECE, or Snell decal as provided by the manufacturer. Decals that are covered or eliminated will be cause for rejection of the helmet. Enclosed cockpit sled drivers must use a current automotive certified helmet meeting Snell SA specification.

NOTICE: For the 2024 season the helmet must have Snell code 2020 or equivalent ECE 22.05 code.

4. For Speed run racing: At least one hundred forty-four (144) square inches of visible area on both the driver's front and back (upper body) will be blaze orange in color at all events. Jackets / Pullovers / Jerseys will be teched lying flat on the ground front and back. Gloves and clothing, along with at least above ankle leather boots are mandatory (above ankle boot must have a minimum of 6 inches of leather above the ankle).
5. Eye protection mandatory; facemasks may be required at the starting line at the discretion of the Race Director. If corrective lenses are required to drive a motor vehicle, the driver will also be required to wear them when racing.
6. Hearing protection is mandatory in all non-stock classes in all types of competition. Recommended for all stock class competition.
7. The use of upper body protection equipment is mandatory, except for enclosed cockpits. The upper body protection must cover all body areas shown in illustration. It will protect the driver in mid-body and back areas and be capable of resisting penetration and dissipating force of impacts while absorbing the shock of most blows. Typical motocross vests do not meet this rule.
8. Shin and knee guards are mandatory. Shin and knee guards will be worn on both legs. The shin guard must extend from the instep to above the kneecap and be constructed of an impenetrable material.
9. Upper Arm Pads and Elbow pads are highly recommended in all forms of racing.
10. Neck bracing is driver preference and is not required.
11. **Drivers, crew members, team owners, staff, and support people may not be physically on the race surface at any time once an event has started. This includes walking the track to inspect for changing track conditions and other concerns. Anyone doing so will be penalized at the race director's discretion. Penalties may range from a verbal warning to ejection from the facility.**

Upper Body Protection That Meets ISR Guidelines [Click Here](#)

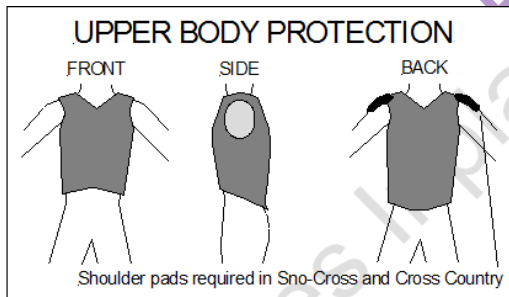

EVS [Click Here](#)

Tek Vest [Click Here](#)

Saf-Jak [Click Here](#)

Leatt Adult [Click Here](#)

Leatt Youth [Click Here](#)

HMK Protective Vest [Click Here](#)

11. Leather suits: See specific requirements in various disciplines.

GENERAL COMPETITION

SIGNAL LIGHT RULES

1. Sanctioning bodies, which employ signal lights, must inform competitors of their signal light protocol before the start of the event. When light signals are used instead of flags, all competitors must be made aware of signal light procedures prior to the race.
1. The following signal lights apply to DRAG racing:
 - a. PRE-STAGE/STAGE-Flashing or non-flashing means stage snowmobiles, be ready to race.
 - b. YELLOW LIGHT- Staged and ready to race.
 - c. GREEN LIGHT- Start of race.
 - d. RED LIGHT-Driver has left the line before green light.
1. It is the driver's responsibility to see that his snowmobile triggers the scoring system properly.
2. Starting and finishing lights must be of a uniform height.

RACE STARTING PROCEDURES

1. All drivers must be assembled on the starting line, ready to race within two (2) minutes of notification of their race (except special events).
2. Snowmobiles may be pushed to the starting line.
3. All participants (including crewmembers entering the start line area, are required to wear eye protection or safety glasses.
4. Snowmobiles must be placed on an approved stand for warm-up and/ or for clearing the track. See CLEANOUT/SAFETY STANDS in this chapter.
5. All snowmobiles on the starting line must have the track and both skis flat on the course surface before starter begins the race.
6. The driver's feet must be on the running boards or stirrups.

START

1. Events that take place under natural lighting will be terminated thirty (30) minutes after published sunset. This rule must be strictly enforced. Furthermore, this rule assumes that there are no other visibility issues other than sunset. If visibility is reduced beyond the prescribed limit by other factors, racing must be halted before the prescribed time.
2. Any conditions that reduce visibility (prior to 30 minutes after sunset) must be considered before continuing to race. Other conditions include (but not limited to) snow dust, ice dust, fog, haze, clouds, mist, falling snow, falling rain, and smoke.
3. It is the Race Director's responsibility to discontinue racing if the visibility falls below the prescribed level at any time during the day.
4. An injured or otherwise incapacitated driver or damaged snowmobile shall be prohibited from racing with exception that if in the Race Director's judgement, the driver or snowmobile is determined not to be a danger to driver's self or any other competitor. The Race Director's decision is final.

LEAVING THE COURSE

1. Drivers should stay on the confines of the marked course. At the discretion of the Race Director, a driver may be disqualified for leaving the confines of the course.

CONTROL OF SNOWMOBILE DURING RACE

1. It is expressly forbidden to drive or push a snowmobile in a direction other than that of normal race traffic.

RACE FINISH

1. The finish line will be clearly marked.

DRIVERS BRIEFING

1. The mandatory meeting (or meetings) will be held at an announced time and place. The Race Director and Race Promoter will conduct it. Descriptions of the course, flags, etc. will be made. An interpreter should be used when needed. Pins, stamps, tags, roll call, random call, etc. may be used to check the identity of drivers at the briefing.

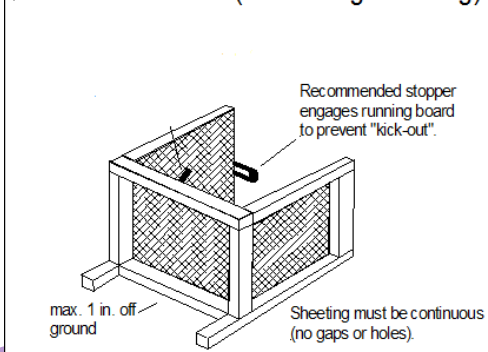
CLEAN OUT / SAFETY STANDS**WARM-UP STAND (not a design drawing)**

1. Snowmobile safety stands that catch and retain track, track lugs, traction components and other items that are thrown by a track are mandatory (see illustration).
2. The stand must be no more than six (6) inches from the rear of the tunnel opening and no more than twelve (12) inches from the track. The safety stand will be constructed of metal equivalent to 6061/T6 aluminum, 1/8 inch thick. Side panels are mandatory, and they must extend at least to the center of the rear axle. Vertical coverage must be no more than one (1) inch off the ground/ice and as high as the snowmobile support device. Coverage must be continuous (no lightening holes). A plywood liner is recommended to help absorb impact. Safety stand must maintain enough height to prevent track encountering ground/ice surface. The stand must be used whenever the rear of a snowmobile is raised to clean out the engine or track.
3. No full throttle operation while snowmobile is on warm up stand.

MISUSE OF PIT PASSES

1. Improper usage of pit or paddock passes will be grounds for discipline.

FIRE EXTINGUISHER

1. Fire extinguishers must be available in pit, paddock/staging and starting line areas. Fire extinguisher minimum size will be five (5) pounds with ABC fire extinguishing capabilities. Fire extinguishers will be in place before the start of the race. All trailers, haulers, enclosed truck bodies, etc. used for transport of racing sleds and their support equipment must have 2 (two)-5-pound ABC extinguishers on board, accessible and serviceable always. **See Outlaw and Pro Extreme 55 for additional requirements.**

GENERAL SNOWMOBILE RULES

These GENERAL RULES apply to all snowmobiles in competition unless so noted. All participants, racers and crewmembers are required to be fully aware of these regulations and must abide by them.

Participants are solely responsible for the condition of their snowmobiles and their competence to operate them.

Where the rules permit or require components or equipment to be installed, replaced, altered, modified, or fabricated, it is the sole responsibility of the driver to select components, materials and/or fabricate the same so that the components will perform safely in competition.

CLASS ELIGIBILITY & SNOWMOBILE ID

1. Unless otherwise specified in specific ISR rules, a snowmobile used in more than one class or division must comply with all rules and safety guidelines for each class or division in which it competes.
2. In stock and stock-based classes, the chassis and engine must have been originally OEM assembled and serial numbered indicating that the snowmobile is a stock qualified unit from the production run of a stock qualified model.
3. All snowmobiles in Modified classes must have serial numbers permanently affixed to the engine and the frame. Duplication of serial numbers is not allowed.
4. If the tunnel, engine, or other serial numbered part is replaced, the serial number must be removed from the replaced part and affixed to the new part.

ENGINE

1. ISR and/or the Race Rules Committees will approve the validity of all engine intake systems.
2. In stock and stock-based classes, the engine must have originated from a stock qualified, OEM produced snowmobile.
3. In stock and stock-based classes, coolant thermostats, regardless of location in the cooling system, may be ran as produced, changed to alternate temperature settings, or completely removed. If removed a control plate/washer to control volume of flow may be installed in its place. This plate shall serve no other function than restricting the flow of coolant.
4. In Stock classes, the OEM for the model exhaust system must remain as produced by the manufacturer and must be fully functional. In Mod classes it will be specifically noted as to which exhaust components may be changed or modified.
5. In classes with individual chamber exhaust for each cylinder, the following minimum standards for straight-thru silencers are required:

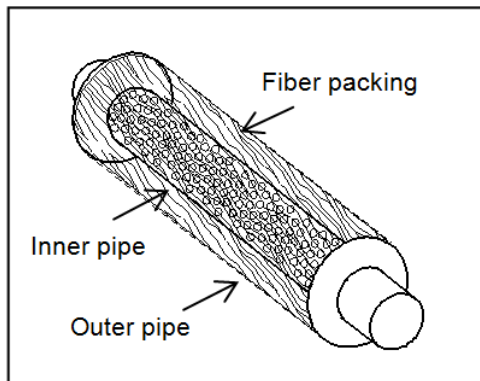

- a. Inner pipe must have at least 15 holes per square inch. Minimum hole size 1/16 in. (Minimum 3/8 in. sound absorbing material around the entire circumference of inner pipe).
 - b. Inner pipe (perforated core) must contact sound absorbing material (fiber or steel wool packing).
 - c. Outer pipe must be at least 3/4 in. larger than inner pipe.
 - d. Minimum silencer length 3 in.
6. In all two stroke engine classes the above functionally silenced rule will be in effect. Exception:(#4 above) In Stock classes factory expansion chamber and after muffler will be required. In Modified two stroke classes the above specifications will be in effect to achieve a "Functionally Silenced Required" operation.
 7. OEM carburetor slide valves and replacement jet components without modification will be allowed in all Stock classes. No modification to carburetor body will be allowed.
8. An adequate return spring on the throttle is required.
The throttle must be a direct mechanical thumb mechanism, which must be located on the rear side (toward the rear of the snowmobile) of the right-hand handlebar. Throttle must be thumb operated. Twist grip throttles not allowed.
 9. All Stock classes - Choke control devices may be disconnected; however, they may not be removed from their mounting location.
 10. No pressure charging allowed unless specified.
 11. When superchargers are allowed, a supercharger restraint system, including a flexible blanket shield, is required to prevent superchargers from being blown free of the engine.

DRIVE

1. Brakes shall always be operative. Brake lever must remain on the left, front side of handlebar.
2. The master cylinder, caliper and disk assembly must be commercially available.
3. Additional brake assemblies may be added. If the secondary brake is on the track drive shaft, the disk may be smaller than 7". Brake disk in any other location must be a minimum of seven (7) inches in diameter. Track drive shaft may be lengthened to accommodate additional brakes.
4. In Modified classes, anytime the brake assembly has been modified or relocated, the brake disk must be covered with a shield capable of retaining an accidental explosion.
5. The disk pad contact surface area may not be reduced more than 15% of the original pad contact surface area.

6. Chains, pulleys, and exposed moving parts will be isolated from the driver and other competitors by shields capable of retaining all accidental explosions and component impacts. Integrity of protective shields shall be at the Race and/or Tech Director's discretion. No holes may be drilled in protective shields.
7. Unless otherwise specified, stock class belt guards are acceptable in Stock classes only.
8. Secondary clutch windage plates may be removed in all classes.
9. Custom clutch guards, clutch guards on purpose-built chassis, and specialty chassis may use Carbon fiber, Kevlar, and other materials as reinforcement of standard clutch guard material and design. Newly designed clutch guards must exceed the specifications and limits established in standard clutch guard requirements, See specific disciplines for details. Each specific clutch guard must be submitted to ISR with digital pictures (both installed and uninstalled, at least four views) and a detailed explanation of design, design limitations, and method and type of fasteners used to affix the guard to the chassis. ISR may request an appointment to inspect on site.
10. Improved Stock and Pro Stock and Pro Mod The clutch cover must be provided with a secure mounting plate. The mounting plate must cover the area below the clutches (from front of cover to rear of cover and width of cover) and be made of the same material as the cover. The cover must be securely fastened to the mounting plate and the mounting plate must be securely fastened to the belly pan.
11. Heavy Mod and Open Mod, Outlaw, and Pro Extreme 55. Clutch cover must have full facial coverage and 360- degree elliptical coverage in the direction of belt travel (see illustration). Belt guard must be .090-inch 6061T6 aluminum or equivalent steel material and be covered with six (6) inch belting. Other belt guard materials not allowed. If the clutch cover is fastened to the existing belly pan, the area below the clutches (from front of cover to rear of cover and width of cover) must be covered with .090-inch 6061T6 aluminum or equivalent. If cover is .125 inch, 6061T6 aluminum or equivalent steel material, belting is recommended, but not mandatory. Clutch cover and related belting must be securely fastened.
12. Backside of clutches must be covered by a portion of the clutch cover or by a bulkhead of comparable material.
13. Aluminum brake disks not allowed.

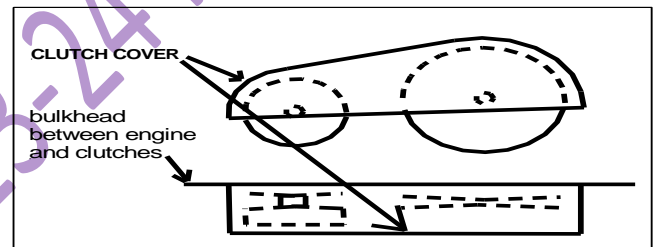
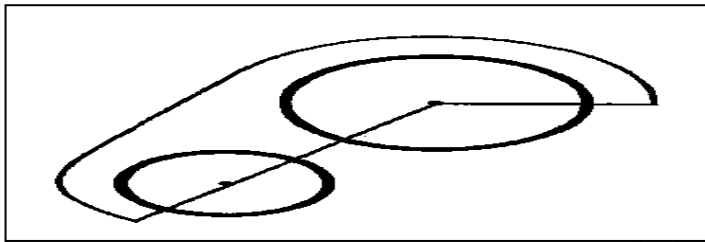

REMOVE AB
SIDE PANEL ILLUSTRATION

SKI SUSPENSION AND STEERING

CURRENT TECHNOLOGY FOX/ OR OTHER BRAND "AIR SHOCKS" ARE CONSIDERED HYDRAULIC DAMPED SHOCKS FOR THIS APPLICATION.

1. All handlebar ends must be plugged.
2. Only steel suspension springs allowed unless otherwise specified.
3. **At safety inspection, Sled must have a minimum ride height of two (2) inches measured at the lowest point of the bulkhead/skid plate. Measurement point to be behind the ski in a 2X2 inch pass through area from ski to ski (left to right). Aero devices are not included in this rule.**

SKIS & SKI RUNNERS

1. Except where otherwise specified, one cutting edge (steering edge) allowed per ski on snowmobiles with independent front suspension. Any ski edge with over 1/2-inch turndown constitutes a cutting edge.
2. A maximum of fourteen (14) inches total length of carbide per ski is allowed. (Unless otherwise specified in specific classes).
3. All ski loops must be at least one (1) inch wide and 5/8-inch-thick or 1-inch diameter round material. The arc of the leading edge of the ski loop must have an outside radius of at least 2 1/8 inches and extend at least 120 degrees upward (see illustration). Plastic ski loops must be affixed with steel bolts.
4. The ski loop must overlap the end of the ski and secure to the underside or it must cover the leading edge of the ski entirely. Exceptions may be noted in class specifics.
5. Metal ski loops must be affixed with steel bolts and not welded (Oval-minimum two fasteners).
6. Metal ski loops must have adequate lateral or vertical support bracing to prevent ski tip loops from dislodging or breaking off.
7. Beam breaker surface for electronic timing must be confined within the ski loop (unpolished, flat black).
8. Ski tip (not including the loop) must be turned up 1.5 inch from the bottom of the ski (not including the keel(s) or ski runner).
9. No part of the ski may contact the body or suspension through the ski's normal range of travel and/or movement.

TRACK SUSPENSION

1. Any OEM type slide rail hyfax may be used as a replacement.
2. Slide rail hyfax can be drilled in all classes.
3. Where allowed in these rules and by local environmental laws, slide rail lubrication systems may be used. No lubrication medium will be allowed that hampers competitor's visibility. No toxic solutions may be used.
4. Only steel suspension springs allowed unless otherwise specified.
5. At safety inspection, track suspension travel will be measured vertically at the rear bumper, two inches of travel must be noted with a max 150 pounds of weight displacement.

TRACK AND TRACTION

CURRENT TECHNOLOGY FOX/ OR OTHER BRAND "AIR SHOCKS" ARE CONSIDERED HYDRAULIC DAMPED SHOCKS FOR THIS APPLICATION

1. Track dimension rules are specified in each chapter. A 1/8-inch maximum variance in the minimum track width requirement is allowed. No cutting, notching, or trimming of the track is allowed, this is class and discipline specific, and is not allowed unless preceded by an ISR Competition bulletin.
2. Unless otherwise indicated, the track must be centered on the centerline of the tunnel in all modified classes. Modified classes are allowed track offset for installation of brake assembly on front driveshaft. In no case may this offset be more than 2 (two) inches, determined from edge of track to inner edge (side) of tunnel. In Stock and Stock-based classes, the track location must be as produced unless otherwise specified.
3. In all forms and classes of racing, track clips and guide clips may be replaced when worn - guide clips may be removed and replaced with track clips - track clips may be removed and replaced with guide clips - the track must retain the original number of clips with which it was produced.
4. In all forms of racing, there are traction device limitations, see specific chapters for details (see Appendix for traction device measurement details).
5. Identification numbers affixed or molded into tracks by the molder of the track must remain completely visible and unmodified. No traction device or other item may be installed over the identification numbers on the track. Identification numbers include model number, serial number and/or any other information applied to the track by the molder.
6. Tracks may not be reversed.

FRAME AND BODY

1. A rear snow flap of sufficient material must be installed in a permanent manner and shall be held down (restrained from rearward movement) to restrain traction components, snow, mud, rocks, and other material thrown from the track at all speeds. Recommended materials are 3/16-inch fiber reinforced rubber belting or 3/16-inch semi-rigid plastic such as HD polyethylene or UHMW polyethylene.
2. The snow flap must overlap the widest part of the rear tunnel opening by at least one inch on each side.
3. The rearward movement of the snow flap must be restrained with steel cable (or similar material) to the frame of the snowmobile. The use of springs and/or elastic material for holding down and restraining snow flaps is not acceptable.
4. The snow flap must be in contact with the course surface when the rider is on the snowmobile. Violation of this rule results in mandatory expulsion from the class.
5. The snow flap on the twin track snowmobile must be reinforced to keep it in proper placement at racing speeds. Two (2) separate flaps may be used on twin track snowmobiles.
6. The maximum overall snowmobile width is 45 inches unless otherwise stated.
7. Where specifically allowed, foot stirrups/foot pegs may be installed. Must be constructed of rigid materials.
8. All modified snowmobiles regardless of class or discipline will be equipped with an upholstered, padded seat minimum thickness one (1) inch, minimum length fifteen (15) inches. OEM seats may be cut down to the design needs of the builder but must meet these minimum standards.
9. Unless otherwise stated, seats in Stock class must be OEM for the model. OEM seats have no requirements for fabric, padding, dimension, or coverage. If the seat meets manufacturers legal design criteria it is legal for any class, stock or modified.
10. Unless otherwise specified, tunnel protective strips may be added to underside of tunnel to protect the tunnel and cooling system from being damaged by traction products.
11. If a braking parachute is required, a recognized manufacturer must have produced it. Tech inspectors may observe the operation of the parachute and inspect for worn or frayed lines, ripped or dirty canopies and worn or ragged pilot chutes. Parachute cable housings must be mounted solidly to the frame or other suitable member; the use of quick pins for parachute mounting is prohibited. The parachute must be mounted in a manner that does not render it inoperative if the snowmobile should lose a track or part of the snowmobile (specifically, mounted above the snow flap and at the center of the rear of the tunnel). The parachute controls will be mounted so they are accessible to the participant in a normal driving position.
12. Parachutes are **Mandatory in OutLaw** and must be deployed each run, and recommended on any snowmobile that can achieve 150 miles per hour and is mandatory for any snowmobile that runs 160 MPH or better. Particular attention must be paid to the mounting of the parachute, so it retains the integrity to remain centered on the chassis when deployed. (This is extremely important to retain control of the sled when deployed.) The parachute controls will be mounted so they are accessible to the participant in a normal driving position,

handlebar control deployment required. Parachutes are to be repacked before each event, and not remain in the pack for extended periods of time. Refer to manufacturer's instructions for parachute use and packing.

13. Improved Stock, Pro Stock and Modified classes. The rear of the tunnel must be enclosed with material comparable in strength to 0.063 aluminum sheet. The tunnel enclosure is required to reduce the possibility of driver's extremities entering the tunnel area. The shaded area (see illustration) must be enclosed. The enclosure shall cover the rear and both sides and extend forward a minimum of 14 inches. The bottom of the enclosure shall be no higher than one (1) inch above the center of the rear axle (with the driver in place). The rear of the enclosure shall be no further than 2.5 inches from the rear of the track.

On race vehicles with longer chassis that use shorter tracks and suspension, rods or other material of sufficient size must be placed in the tunnel horizontally every 2.5 inches from rear of track to rear of tunnel enclosure. Clarification to above rule: Having only one bar at 2.5" still allows extremities to get in the track.

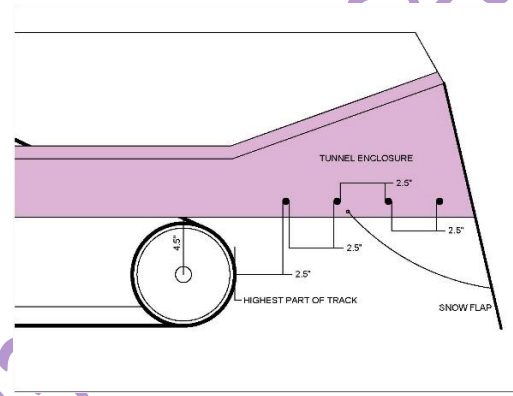
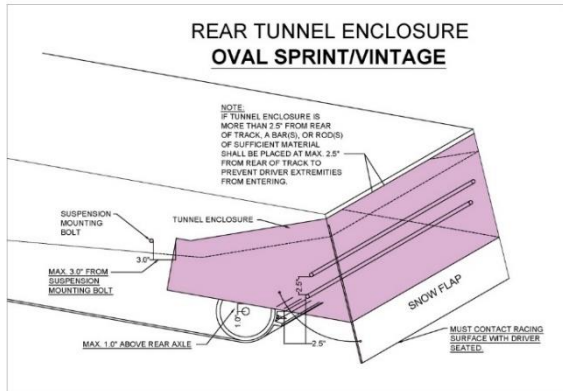

ENCLOSED COCKPIT FRAME AND BODY

1. A quick release seat belt/ shoulder harness (aircraft-type, automotive race type) is mandatory on all enclosed cockpit snowmobiles. All safety belts/shoulder harness installations must be mutually compatible (originally designed to be used with each other). Installations not allowed where the harness is sewn, fastened or where the safety belt is fed through the loops in the harness. For harness installations see illustration. Only those units that release all four (or five) attach points in one motion are allowed. Shoulder harnesses must be securely mounted to the frame, cross member, or suitable reinforced mounting, and installed to limit driver's body travel both upward and forward. Belts and shoulder straps must be 3-inch minimum width.
2. Quick release arm restraints are mandatory.
3. Under no circumstances are bolts to be inserted through belt webbing for mounting.
4. It is recommended that all belts and harnesses be covered with fireproof material.
5. An abrasion plate is mandatory on seat belts where they are wrapped around the frame and would be exposed to rubbing on the track or by a rotating component.
6. All enclosed cockpit snowmobiles must be equipped with a regulation on board fire extinguisher and must be manually controlled. The system must be halon 1301 or 1211 and mounted per manufacturer's specifications with the primary nozzle(s) directed to protect the participant while in the driving position. See OVAL OUTLAW rules for variations and exceptions.
7. Fuel tanks must have a pressure cap and be vented to the outside of the body or have built in check valve.
8. All roll cage structure must be designed to protect the participants from any angle, three hundred sixty (360) degrees. Flush grinding welds not permitted. It is recommended that all cage welds be gusseted. Must have a roll bar four (4) inches above driver's head (see illustration). An approved Fire-Retardant Suit, (fire suit) must be used and must be the final layer of clothing on the driver during competition. No other clothing may be worn over the fire suit.

IGNITION & ELECTRICAL

1. All snowmobiles must be equipped with a tether switch that must always be attached to the operator and be operable. The switch must "kill" the engine by disconnecting the ignition system when the operator and the snowmobile become separated. It is the responsibility of the driver to make certain that the tether is attached to everyone who starts the engine or operates the snowmobile.
2. Maximum tether cord length will be 4 feet except where noted otherwise. Verification of tether cord length will be determined at tether cord's fully extended length.
3. The tether cord will be securely fastened to the driver.
4. The tether switch will be securely mounted in a location on the snowmobile other than on the handlebars or steering column.
5. All snowmobiles must have a handlebar mounted button (on/off) kill switch on the right side within thumb reach (this is in addition to your

- tether switch).
6. Wet cell must be enclosed in a non-conductive battery box. Positive terminal must be shielded. Battery box must be securely held in place.
 7. On snowmobiles with enclosed cockpits, it is mandatory to have a functional kill switch that will terminate ignition if the snowmobile rolls over, this is in addition to the tether switch.
 8. Unless otherwise specified, electric start parts including motor, solenoid, battery, battery bracket, wiring, and ring gear may be removed. No machining, cutting, or grinding allowed for removal.

FUEL REGULATIONS

NOTICE: It is advisable for all competitors to have their fuel tested at the event, before competing.

FUEL TESTS

SUBJECT: Fuel Clarification

All classes (see exceptions below):

Only a commercially available pump gasoline that complies with these rules is allowed. (The term "pump gasoline" includes fuels dispensed from service station pumps and racing fuels that are commercially available in fuel cans and drums.) The gasoline may be mixed with petroleum, vegetable, or synthetic based lubricants. The use of oils, fuels (including gasohol), and additives that provide power-boosting characteristics are strictly forbidden. Fuel with ethanol may be used up to 10% (ten percent) in all Speed Run classes.

In these specific classes, Pro Extreme 55, and Outlaw: VP Import, Q 16, may be used as an alternate fuel. All standard fuel tests still apply as they pertain to the type of fuel used. All standard fuel tests still apply as they pertain to the type of fuel used. In the case of "Import" ISR has on file the spectrograph footprint of this category of fuel and competitors using "Import" may be required to supply samples for comparison purposes. VP Import fuel needs to be used as produced by VP fuels (no cutting or blending.)

In Outlaw VP Import, Q 16, Methanol / Nitro may be used as an alternate fuel. [ISR Rule Clarification Bulletin Click Here](#)

WARNING: Gasoline, lubricants, additives, and fuel test reagents are all potentially hazardous materials. Anyone handling them should be aware of the hazards and act accordingly. Race Rules Committees and ISR establish these guidelines and recommended test procedures, but do not assume liability for injury or death caused by the handling of these materials.

Any or all these tests may be employed. Test results may be confirmed from time to time using an infrared spectrometer.

IF ANY OF THESE FIELD TEST ARE FAILED BY A PARTIAPANT HE WILL BE DQ'ED FROM ALL CLASSES THAT HE PARTICAPATED IN FOR THAT DAY.

1. ELECTRICAL CONDUCTIVITY (DI ELECTRIC CONTENT)
2. CERIC NITRATE REAGENT TESTING
3. REAGENT D TEST FOR DIOXANE
4. WATER SOLUBILITY TESTING
5. ANY OTHER TEST APPROVED BY RACE RULES COMMITTEES

ENFORCEMENT, DISCIPLINE AND VIOLATIONS

All participants are subject to disciplinary action for violations of these rules in accordance with the sanctioning organization's bylaws. Penalties may include suspensions, fines, loss of points, disqualifications, or any combination thereof. The nature of the penalty is determined by the gravity of the offense and its effect on the safety and good reputation of snowmobile racing. The violations hereinafter set forth are subject to the penalties noted.

EJECTION FROM RACE SITE

1. The Race Director has the right to eject any person(s) from the pit, paddock (staging area) or racetrack area.

CONDUCT OF PARTICIPANT (OFFICIALS, DRIVERS, CREWS, ETC.)

1. Participants are solely responsible for the condition of their snowmobiles and their competence to operate them.
2. No driver may, at any time, ride/drive in such a manner as to endanger life or limb of other riders, officials, or the public.
3. Vulgarity, derogatory or offensive language will result in disciplinary action, ejection from race site and be subject to fines and penalties.
4. Any participant that threatens bodily harm or assaults any official, driver, crew, etc. will be subject to disciplinary action, ejection from race site and be subject to fines and penalties.
5. Clothing displaying vulgar language is not allowed.

DRIVER LIABILITY RELEASE OVENANT NOT TO SUE

1. *The driver/pit crew, in filing an application to enter the event, elects to use the course of the event at driver's /pit crews own risk, and thereby releases the sanctioning organization together with their heirs, assigns, officers, representatives, agents, tech personal, employees, and members, sponsoring organization and owners of properties on which sanctioned events are to be held from all liability from injury to person, property and/or reputation from tech decisions that may be received by said entrant and from all claims of said injuries to the parties listed above growing out of, or caused by any construction or condition of the course over which the event is held and or piece of equipment that participant entered into competition.*
2. *Drivers/pit crew and other participants further acknowledge and fully understand that there may also be other risks that are not known or foreseeable at this time, and the above and released persons cannot control these risks, nor have the released persons judged the participants' skill level or ability prior to allowing the participants to participate and consequently is not in a position to guarantee the participants' personal health or safety during the programs, events, or activities. DRIVER/PIT CREW KNOWINGLY AND VOLUNTARILY ASSUMES ALL SUCH RISKS, BOTH KNOWN AND UNKNOWN, ANTICIPATED AND UNANTICIPATED, EVEN IF ARISING FROM THE NEGLIGENCE OF THE RELEASED PERSONS OR OTHERS, AND THE PARTICIPANTS ASSUME FULL RESPONSIBILITY AND LIABILITY FOR THE PARTICIPANTS' PARTICIPATION.*
3. *In consideration of permission and as a requirement of participation in sanctioned events, drivers, pit crew and other participates hereby covenant and agree not to sue the sanctioning organization, or its heirs, assigns, officers, representatives, agents, employees, and members, sponsoring organization and owners of properties on which sanctioned events are to be held, and further agree to fully release, indemnify and hold harmless those persons from any and all causes of action, demands, claims, and loss of injury to person or property or damages, of any nature whatsoever, whether the participation is supervised, unsupervised, however the injury is caused, including, but not limited to the negligence of any released persons.*

DRIVER RESPONSIBILITY

1. The driver has the responsibility for the actions of his crew. It is the driver's responsibility to see that all crewmembers are aware and abide by all rules and guidelines.
2. The condition of a snowmobile is the responsibility of the driver. A driver may be disciplined if driver's snowmobile is modified to defraud the officials or other competitors.

FRAUD, BRIBERY & ILLEGAL ASSISTANCE

1. In addition to non-compliance with any of the above regulations or rules, the following offenses shall be considered a breach of regulations subject to disqualification.
 - a. Bribing or attempting to bribe anyone connected with the race or accepting or offering to accept a bribe.
 - b. Competitor accepting any kind of assistance that aids in snowmobile operation during the race.
 - c. Any fraudulent proceedings or act of prejudicing the interest of the race.

INTOXICATING BEVERAGES & DRUGS

1. Drinking of intoxicating beverages is strictly forbidden by any participant. Anyone showing evidence of having used an intoxicating beverage must leave the premises (specifically pit, paddock (staging area), warm up area, tear down and racetrack) immediately and be subject to disciplinary action by the disciplinary committee. This shall be in effect through the final inspection of snowmobiles.
2. Possession or use of illegal drugs or drug substances, as defined below, is prohibited in any form, by any participant, on the race facility, or in any area considered to be used in the operation of the race facility, such as parking lots or leased properties.
3. Illegal drugs are these substances defined and prohibited by state/provincial and/or federal law.
4. Any person found to be in possession or under the influence of an illegal drug or drug substance on race facility property, as defined above, or any person who is arrested by duly constituted authorities and charged with possession and/or use of illegal drugs or drug substance or any person who is formally charged by a court of law with illegal drug violations, shall be subject to suspension from competition and eviction from the race facility, and denial of further entry to the race facility for a period determined by the disciplinary committee.
5. Any participant who is formally charged by a court of law with an illegal drug violation, upon notification to the ISR Advisory Board, shall be suspended from all forms of participation at any ISR event until such time as the charges are fully adjudicated through the legal process. Any conviction of a formal drug charge by such will be prohibited from taking part in any ISR or affiliated event for a minimum period of three (3) years from date of conviction.
6. Any participant suspended for violation of these rules may be granted an appeal hearing by a board of officials designated by the ISR Advisory Board, provided the suspended participant requests such hearing in writing, within fourteen (14) calendar days of the date of suspension. It is the responsibility of the suspended party to make such a request if a hearing is desired.
7. The cost of convening the board of officials will be borne by the participant prior to the convening of the board.
8. A participant suspended for violation of these rules, EXCEPT IN THE CASE OF PERSONS CHARGED WITH SELLING DRUGS, may, as the result of a decision reached through the hearing process detailed above, be reinstated, if it is mutually agreed that the participant (at his own expense) will produce documentation from a physician licensed within the state or province, certifying that he or she is drug independent, as a result of random and periodical examinations and urinalysis testing made at the request of the ISR Advisory Board.
9. If a participant is using prescription drugs on advice of a physician, such use must be reported to the Race Director prior to the participant's entry into any ISR activities. Failure to notify will subject the participant to penalties as prescribed above.
10. A participant is any person taking part in any event sanctioned by or affiliated with International Snowmobile Racing, Inc., in any form,

including but not restricted to drivers, snowmobile owners, mechanics, crew members, sponsors, track officials, pit area personnel, manufacturers and press representatives. All such persons shall be considered public figures that have by their own choice become involved in the snowmobile racing events, with the full understanding that he or she must abide by the rules and regulations established and published by ISR. All participants are responsible for their personal conduct.

RACE DIRECTOR AUTHORITY

1. The Race Director and Technical Director will be certified by the sanctioning organization.
2. The Race Director shall be responsible for the conduct of the race. He shall have the right to make the final determination concerning all aspects of the race and the race facility, including design (these rules and regulations notwithstanding). The Race Director is defined as the overseer/controller of the actual track operations during an event. He has prevue over all aspects of the race and interpreting rules that are applied. He may be a track owner/ or contract manager of a facility, however, "Race Directors" that are of administrative or business side of the event, although they may be referred to as race directors are not the on-track event director. In any case ISR certification is required.
3. He shall have the voice of authority to discipline the participants for violation of the rules. Such discipline will be limited to disqualification of a participant and/or exclusion from an event.
4. Official race results shall be approved by the assigned Race Director and a signed copy will be returned to the promoter for announcement and distribution.
5. Race Director may not have vested interest in the outcome of an event over which he/she officiates. He/she may not officiate over a class in which he/she has a vested interest.
6. Race Directors may compete in events other than those in which they officiate.
7. The Race Director may cancel any race or the complete event for reasons of safety regarding competitors or spectators, and in such case shall determine the awards, if any. The Race Director may shorten the race for any reasons of safety but must give drivers adequate notice in advance.
8. A Race Director may judge the mechanical integrity of all timing equipment.
9. Only Drivers (no other participants) will have discussions with the Race Director about protests, and driving complaints, etc., and may approach the Director before the day's events, after an event, or at the direction of the Race Director.
10. The Race Director has the authority to judge the racing abilities of competitors and take appropriate action to ensure the safety of the event.
11. The Race/Tech director shall have the authority to determine structural integrity.
12. The Technical Director shall carry and be responsible for the official specifications and certain instruments for measurements concerning verification and control of contestants' snowmobiles. The Technical Director may not officiate over a class in which he has a vested interest.
13. Technical equipment and specifications will not be used for any purpose other than the conduct of the sanctioned event.
14. Decisions of the Race/Tech Director may be reviewed by the board of the sanctioning body.
15. Decisions made at an event shall not be overturned without a formal appeal. Notice of the appeal process shall be given and a suitable period for all parties to prepare must be allowed.

NO EXPRESS OR IMPLIED WARRANTY OF SAFETY SHALL RESULT FROM PUBLICATION OF OR COMPLIANCE WITH THE RULES AND REGULATIONS IN THIS PUBLICATION. THEY ARE INTENDED AS A GUIDE FOR THE CONDUCT OF THE SPORT AND ARE IN NO WAY A GUARANTEE AGAINST INJURY OR DEATH TO SPECTATORS OR PARTICIPANTS.

SPEED RUN COMPETITION

The intent of these classes is to establish races in which all can compete at their level of personal and equipment ability. The class structure is organized in such a way as to enable as many snowmobiles as possible a place to successfully compete.

If class rules are not followed, the class name shall not be used, and the class shall be run as a specialty class with ISR's prior approval. Based upon safety and competition, stock snowmobiles manufactured prior to 15 years of the current model year will not compete in Stock classes but may compete in other classes.

SPEED RUN CLASSES

STOCK CLASSES

CLASS	MAX. cc	CARBS	EXHAUST

	440 (fan)	OEM 34mm or 36mm EFI	OEM (Must be single expansion chamber)
Stock 440	440		
Stock 500	500	OEM 38mm or 40mm EFI	
Stock 600S	600	OEM	
Stock 600	600	OEM	OEM
Stock 700	700	OEM	OEM
Stock 800	800	OEM	OEM
Stock 900	900	OEM	OEM
Stock 1000	1000	OEM	OEM

IMPROVED STOCK CLASSES

CLASS	MAX. cc	CARBS
Improved Stock 440	440	OEM 34mm or 36mm EFI
Improved Stock 500	500	
Improved Stock 600	600	OEM
Improved Stock 700	700	OEM
Improved Stock 800	800	OEM
Improved Stock 1000	1000	Any carbs

OPEN MOD CLASSES

CLASS	MAXIMUM CC
Open Mod 440	440
Open Mod 500	500
Open Mod 600	600
Open Mod 700	700
Open Mod 800	800
Open Mod 1100	1100

PRO STOCK CLASSES

	MAXIMUM CC
Pro Stock 500	500
Pro Stock 600	600
Pro Stock 700	700
Pro Stock 800	800

Pro Stock 1000	1000
Pro Stock 1500	1500

SPECIALTY CLASSES / SANCTIONS

NSSR WILL RUN 2 STROKE AND 4 STROKE CLASSES IN THEIR RESPECTIVE CLASS WITH 1000 FOOT TRACKS

1. All special sanctions and specialty classes must be approved in writing by ISR and the rules committee before competition.
2. Can be any snowmobile Speed Run class or event that does not fall under any of the specific circuits or classes but meets established safety standards, applicable laws and/or approved insurance coverage.
3. Stock 700S (single pipe)
4. Stock 800S (single pipe)
5. Pro Stock Classes (with pound per cc limits)
 - a. Piston Port- .72 pounds per cc
 - b. Crankcase Reed Induction - .75 pounds per cc
 - c. Rotary valve or 4 Cylinder - .78 pounds per cc.
6. Super Stock Classes 1, 2, and 3
7. Dial in Class
8. Pro Extreme 55 Class
9. Open Fuel Classes 1 and 2
10. Unlimited Class (Contact ISR for details)
11. Lake Racer
12. Top Gun

REGISTRATION AND ENTRY

1. The entry fees for all classes will be regulated by event promoter, and/or Sanctioning Body.

PAYBACK

1. Amateur Trail Stock – Trophies only
2. Stock, Improved Stock, Pro Stock and Open Modified Classes are payback classes.
3. Promoter must inform entrants in writing of all payback details.

GENERAL COMPETITION AND SAFETY

1. Starter will notify the driver when he can proceed on his run. Four (4) attempts, five (5) minutes per attempt, maximum will be allowed to complete an official record attempt to ensure the validity of all new records. A back-up performance within two (2) percent of the new mark is required at the same event. Any snowmobile traveling one hundred (100) feet or more from the starting line, down the track will be considered as an attempt/run.
2. One-half (1/2) hour notification will be given prior to the close of the race.
3. **The tether cord will be securely fastened to the driver. D rings/tabs on gloves and jackets are not designed for the abuse encountered during competition and accidents. It is required have your tether cord mounting location on your jacket or upper body protection in a reinforced area. A race or tech director may disapprove of the attachment method at any time. Drivers will not be allowed to compete until the attachment situation is rectified.**
4. **Drivers, crew members, team owners, staff, and support people may not be physically on the race surface at any time once an event has started. This includes walking the track to inspect for changing track conditions and other concerns. Anyone doing so will be penalized at the race director's discretion. Penalties may range from a verbal warning to ejection from the facility.**

VIOLATIONS & DISQUALIFICATIONS

1. Runs will be disqualified for the following:
 - a. Contact with course barriers, timing equipment, or course markers will automatically disqualify the run. Leaving the confines of the course, run-off area or the return lane.
 - b. Participant's feet leave the running boards or foot pegs during a run.
 - c. Losing control of the snowmobile.
 - d. Snowmobile or component failure that jeopardizes the participant or his/her ability to control the snowmobile.

- e. Participants crew member found in a restricted area.
2. Participants will be disqualified from the event for the following reasons:
 - a. Failure to abort a run that may result in injury to the participant, other participant, race official or spectator.
 - b. Mandatory teardown and inspection of the snowmobile breaking the record in its respective class, during a qualified official record run. Teardown is by protest only at the other events or at the discretion of the Race Director.
 - c. Participant leaves the starting line before the Race Director has given approval.
 - d. Refusal to comply with mandatory teardown and technical inspection. Refer to GLOSSARY for definition of SNOWMOBILE.

GENERAL SNOWMOBILE REQUIREMENTS

ENGINE

1. Participant using external cooling system must use a catch pan to stop any coolant from leaking onto ice/ground when in use or being disconnected.

NOTICE: Sound limitations may be changed at any time.

DRIVE

1. The snowmobile must be propelled by a variable ratio belt transmission (CVT). See specific detail in Outlaw and Pro Extreme 55
2. (Improved Stock and Pro Stock) The clutch cover must be separate of cowl configuration, and cover clutches down to center of clutch bolt or below. Must be .090-inch 6061T6 aluminum or equivalent steel material and be covered with (6) inch belting. Snowmobile with removable side panels may bolt clutch cover to side panel to meet this requirement.
3. (Improved Stock and Pro Stock) The clutch cover must be provided with a secure mounting plate. Mounting plate must cover the area below the clutches (from front of cover to rear of cover and width of cover) and be made of the same material as the cover. Cover must be securely fastened to mounting plate and mounting plate must be securely fastened to the belly pan.
4. (Heavy Mod and Open Mod) Clutch cover must have three hundred sixty (360) degree elliptical coverage in the direction of clutch/belt travel. Clutch cover must be .090-inch 6061T6 aluminum or equivalent steel material and be covered with (6) inch belting. If the clutch cover is fastened to the existing belly pan, the area below the clutches (from front of cover to rear of cover and width of cover) must be covered with .090-inch 6061T6 aluminum or equivalent. Clutch cover .125 inch (6061T6 aluminum or equivalent) thick is highly recommended. Clutch cover and related belting must be securely fastened.
5. Backside of clutches must be covered by a portion of the clutch cover or by a bulkhead of comparable material.

TRACK SUSPENSION

1. Slide rail lubrication systems may be allowed based upon sanctioning body rules and state and local laws and regulations.
2. Dual limit straps required in all classes.
3. Spring tension blocks may be removed on all Arctic Cats 1995 or older.

TRACK AND TRACTION

1. Traction device maximum height above the track lugs (see appendix):
 - a. $\frac{3}{4}$ inch for Stock, Improved Stock, Pro Stock, and Open Mod up to 700.
 - b. $\frac{7}{8}$ inch for Open Mod 800 and 1000.
2. In Stock class, track width is as produced for the model. In all other classes, there is no minimum track width. All tracks must be commercially available. Track width must remain as produced by the molder of the track.
3. No plate on a rubber track can be larger than 2 $\frac{1}{4}$ inches in width and length.
4. No cleated tracks allowed. All tracks must be commercially available, molded, one-piece rubber tracks.
5. Plates welded onto track clips must be no longer or wider than track clip. Only one plate allowed per track clip. Only one traction point allowed per weld-on plate. Rubber between ends of track clip may be trimmed to allow welding on of stud plate.

STOCK GENERAL RULES

1. The snowmobile must have original OEM for the model engine, hood, frame, cowl, gas tank, carburetion, airbox, suspension and variable speed converter. Named components must be OEM for the model and year, or properly filed OEM replacement parts. that supersede the original OEM parts. Factory options are not allowed.
2. Factory 600 Super Stock Race Sleds will run in separate 600 class or will add 25lbs to compete combined. (Affiliates Choice)
2. All snowmobiles must comply with the GENERAL RULES AND REGULATIONS SECTION.

3. Drivers in the Stock classes must weigh a minimum of 180 pounds including protective gear. If the driver does not meet the weight requirement, ballast must be added to the snowmobile. Additional fuel and/or optional marginal snow wheels added to the slide rails may be used as ballast.
 4. The snowmobile must meet the weight as filed by the manufacturer.
Twenty (20) pounds will be added to the snowmobile weight (as filed by the mfr.) for fuel and studs.
- NOTICE: Weights are reviewed annually.**
5. Commercially available gasoline that is reformulated with up to 10% ethanol are allowed in stock.

ENGINE

1. No component of the engine may be altered, changed, reduced, or enlarged from the engine manufacturer's original stock specifications, nor may any additional components be added to the engine. Blueprinting of engines is not allowed. No removal of material whatsoever will be allowed. This is to include polishing, port matching, deburring, glass or sand blasting surfaces or material removal for engine balancing or other reasons.
2. Maximum cylinder overbore for wear cannot exceed .020 inches (1/2mm).
3. Replacement pistons must be stock OEM for the model.
4. There will be no more than one-cylinder base gasket to a cylinder. No changes in engine dimensions can be made by gasket adjustments.
5. Spark plugs do not necessarily have to be OEM equipment in Stock classes.
6. A maximum of one venturi per cylinder will be allowed in Stock classes. Any exception must be approved in writing by ISR.
7. OEM carburetor slide valve and replacement jet components, without modification, are allowed in all classes. No modification to carburetor body will be allowed. OEM fuel Injection as provided OEM must be used (See #8 below). OEM power adders/Turbo's Must be used with no alterations. (clarification)
8. On snowmobiles with OEM electronic fuel injection, commercially available electronic control modules may be added to the OEM ECU for increasing or decreasing fuel delivery and allowing ignition mapping changes.
9. Airbox may not be modified. Air box may be removed. If removed, must be replaced with commercially available foam/paper/fabric air cleaners. Individual air cleaners should be used on each carburetor with suitable connecting adaptors if necessary. A redesigned ram air box is not allowed.
10. No additional fuel pumps may be added to stock carbs.
11. Oil injection pump must remain in place and remain functional. Lines may be removed and plugged. Oil injector nozzles may be removed, and holes may be plugged. Premix gasoline may be used.
12. Engine must retain OEM for the model cooling system.
13. On liquid cooled snowmobiles, except for quick disconnects and flow directional valves, the cooling circuits cannot be modified or removed. Thermostats may be removed. When the snowmobile is on the course the cooling fluid must flow unobstructed throughout the entire cooling system (no short circuiting).
14. Harmonic balancer may not be removed.
15. The complete OEM exhaust system must be used as furnished and filed by the manufacturer for the model. (This is construed as to include the exhaust gaskets at engine and exhaust system mating surfaces)

DRIVE

1. Any combination of springs, weights and ramps may be used in the clutches. There is no maximum clutch engagement RPM.
2. No machining on clutches to accommodate springs and weights.
3. No machining, grinding, cutting, or welding allowed on clutches unless otherwise specified.
4. Metal may be removed but not added to primary clutch ramps or flyweights.
5. Secondary clutch cams may be cut to any angle. Billet helixes allowed.
6. No overdrive machining.
7. Drive belt need not be OEM for the model.
8. Any drive chain and sprockets may be used.
9. Track sprockets/drivers must remain OEM for the brand.
10. Track drive sprockets may be changed to use a 2.52-inch pitch drive to accommodate a designated R rated track. Sprockets must be OEM for the brand and of the same material and diameter (+/- 0.5 inches) as the OEM sprockets for the model.
11. OEM for the model brake system including master cylinder, caliper, and disk, must remain as produced by the OEM and must be fully functional and mounted in the OEM location. No other brake components may be added.

SKI SUSPENSION & STEERING

CURRENT TECHNOLOGY FOX "AIR SHOCKS" ARE CONSIDERED HYDRAULIC DAMPED SHOCKS FOR THIS APPLICATION.

1. Any steel suspension springs allowed. OEM for the model design concept must be maintained.
2. Functional suspension required.
3. Shocks must remain OEM for the model and remain in the OEM location. On rebuildable shocks, spacers may be added internally to limit rebound travel, but not compression travel.
4. Handlebar extensions are allowed. All ends must be plugged. (See diagram in GENERAL RULES AND REGULATIONS SECTION).

SKIS & SKI RUNNERS

1. Aftermarket skis allowed. Skis must be commercially available and marketed through normal sales activity. Minimum aftermarket ski length is 40 inches. Ski width may not be trimmed. Skis may not be interchanged between brands. Replacement ski must be the same material as OEM ski for the model (i.e., plastic to plastic, steel to steel). Lower ski surface must remain OEM material.
2. Skis may be reinforced but must remain in the original configuration. This reinforcing must be on upper surface of the ski only.
3. Ski runners may be removed or replaced. Bolt holes may be covered.
4. Ski skins not allowed unless OEM for the model.
5. Ski lubrication not allowed.
6. If ski runner (wear bar/carbide) does not go up through the ski, ski runner front must be 2 inches off the ground (with machine at rest) to prevent ski runner from digging into the ground.

TRACK SUSPENSION

CURRENT TECHNOLOGY FOX "AIR SHOCKS" ARE CONSIDERED HYDRAULIC DAMPED SHOCKS FOR THIS APPLICATION.

1. The complete suspension must be used as furnished and filed by the manufacturer. There will be no suspension options permitted in Stock classes. Track suspension may be located anywhere in the tunnel where the manufacturer has drilled, partially drilled, or marked for mounting holes. Pre-drilled plates may be drilled out to facilitate suspension adjustment. Pre-drilled backing plate holes may not be enlarged or slotted.
2. Any steel or titanium suspension springs allowed. Torsion springs (not coil springs) may be shortened at the long end to prevent contact with the track. OEM for the model design concept must be maintained.
3. Functional suspension required.
4. Marginal snow wheels and related hardware may be added to or removed from slide rails. Structural integrity must be maintained.
5. Rear axle idler wheels must remain OEM for the model. OEM for the model rear idler wheels may be added to the rear axle. For durability purposes rear axle idler wheel and axle assembly may be replaced with another brand OEM rear axle or wheel assemblies.
6. Shocks must remain OEM for the model and remain in the OEM location. On rebuildable shocks, spacers may be added internally to limit rebound travel, but not compression travel.
7. No device may be added that stops the suspension from going thru its normal bottoming action.

TRACK & TRACTION

1. A track manufacturer who offers this product commercially available may submit one track design with clip configurations to ISR Race Rules Committee for approval. Approval will be based on the track manufacturer's adherence to rib/lug height, track durometer, track weight and other factors.
2. The track must be OEM for the year and model or one of the designated tracks listed below: CAMOPLAST: 9811R, 9812R, 9813R, 9814R, 9843R, 9844R, 9845R, 9846R, 9862R, 9902R, 9926R, 9927R, 9810R, 9861R, 9904R, 9929R, 9937R, 9976R, 486700025, 486700040 KIMPEX: 04-848K.
3. To be eligible for competition, the above listed tracks must be commercially available.
4. No cutting, trimming, or shaving of the track or rubber studs/snow lugs allowed. The track must be used as produced by the molder of the track. Acceptable traction products allowed. **[EXCEPTION]** Snow Drag, approved trimming, cutting, shaving allowed.
5. Minimum lug height from the flat of the track is 0.50 inch, the maximum lug height of a replacement track is 1 3/8 inch.
6. The track may not be reversed.
7. Track clips and guide clips may be replaced when worn. Guide clips may be removed and replaced with track clips. Track clips may be removed and replaced with guide clips. The track must retain the original number of clips with which it was produced.

REVISED RULE

8. **The 11.250 x .250 thick Dayco flat belt track, or any variation of it (Dayco track) is no longer allowed for competition. The Camoplast/Camso version of the flat belt track is legal for competition. If an updated version of a flat belt track of any manufacturer is to be considered for future seasons use it must be submitted to ISR 6 months before the start of the next season for evaluation and allowable use. (Example: For the 2024 season submission would need to be by June 30, 2023.)**

FRAME & BODY

1. Snowmobile width shall be as produced by the OEM manufacturer.
2. Any chassis alterations, additions, or removals, which alter stock appearances or dimensions are not allowed.
3. Tunnel can be repaired but must remain OEM for the model length.
4. A rod may be placed in the roll on the edge of the running board.
5. No additional venting allowed.
6. Protective taping or screening will be restricted to the external openings only.
7. The OEM fuel tank is the only tank that can be used for fuel supply. The oil tank may not be used as fuel tank.

IGNITION & ELECTRICAL

1. Ignition must be OEM for the year and model.
2. CDI/ECU module may be reprogrammed.
3. No aftermarket device allowed which interrupts ignition for launch control or traction control unless OEM for the model.
4. Lighting coil must remain in place.
5. Stock snowmobiles will be allowed to add or remove tachometers, speedometers, or heat gauges (openings must be closed).
6. Electrical wiring must remain in place.
7. Headlight assembly may be removed (opening must be closed). Headlight consoles are not considered part of headlight assembly.
8. Aftermarket sensors of any type can only be installed in the wye pipe or the exhaust canister.

SUPERSTOCK RULES**GENERAL**

1. Super stock sleds must retain their stock appearance unless otherwise specified. Engine and qualified stock chassis must 1987 or newer.
All sleds competing in Super Stock must comply with GENERAL RULES AND REGULATIONS SECTION.
2. There will be no machine movement between these classes during the event. Movement will be allowed from race event to event.
3. There will be two (2) Super Stock classes.
 - a. Super Stock – 700-1000cc displacement any number of cylinders and induction style. Stock tracks and suspensions only, Machine and participant will weigh .80lbs per cc.
 - b. Super Stock Twin – 700-1000cc displacement limited to twin cylinder machines. Any induction style allowed. Stock tracks and suspensions only. Machine and participant will weigh .75lbs per cc.
4. Weight rules are subject to change at any time for the purpose of fair competition in Super Stock classes and will be adjusted during the season if necessary.
5. Ballast – If machine and driver do not meet the minimum weight requirements of the class, additional ballast must be added to the machine.

ENGINE

1. Engine must be a qualified stock 1988 or newer.
2. Belt centers and offset may be adjusted with modified engine mounts.
3. Engine must be in original OEM location.
4. Engine components allowable for modification or replacement are as follows:
 - a. Bearings
 - b. Rods
 - c. Pistons (any commercially available piston is allowed.)
 - d. Pins
 - e. Rings
 - f. Gaskets
 - g. Manifolds (intake)
 - h. Carburetors/Fuel injection
 - i. Motor mounts
 - j. Ignition
 - k. Water pump (may be removed)
 - l. Fuel pump
 - m. Exhaust
 - n. Crankcase, crankshaft, rods, cylinders, and heads must match the brand of the chassis. Cylinder spacers are allowed with stock cylinders.
 1. Any OEM for the brand crankcase will be allowed and may be modified provided the induction concept is retained; welding to effect repairs is allowed.
 2. Any carburetor is allowed.

3. A maximum of one venturi or one throttle body is allowed per cylinder. Any modification is allowed to the original carburetor casting.
4. Cylinders must be 1988 or newer and be OEM for the brand of the machine.
5. No aftermarket cylinders will be allowed in the class.
6. Welding and machining to effect repair is allowed. Welding to change existing porting is allowed provided it does not change the number of cylinders or the original concept of the engine.
7. Any OEM head for the brand will be allowed. Custom made combustion chambers will be allowed. Custom made combustion chambers will be allowed but must be used in conjunction with the OEM head casting. Custom chambers must not be visible on the assembled engine. Multiple spark plugs not allowed unless OEM.
8. Air box may be modified, replaced, or removed.
9. Aftermarket fuel injection systems will be allowed.
10. A functionally silenced exhaust is required.
11. Exhaust pipe must not protrude more than three (3) inches beyond the chassis or hood configuration.
12. A small fuel cell may be used in lieu of the OEM tank but must remain clearly visible for tech inspection.
13. The crankshaft stroke may be altered.

DRIVE

1. Stock OEM primary clutches may be modified (no RPM limit) or may be replaced with any stock qualified primary clutch. Secondary clutch may be aftermarket and commercially available.
2. Drive chain may not be replaced with belt.
3. Chain case must be OEM for the brand and be 1988 or newer.
4. Exact OEM shaft centers and position must be maintained.
5. Jackshaft may be replaced, subject to the metal substitution rule/
6. Welding on jackshaft is not allowed.
7. Drive axle may be replaced subject to metal substitution rule. Must remain in exact OEM location for the model.
8. Chassis must be a qualified 1988 or newer.
9. Chassis reinforcement will be allowed (metal substitution is allowed) Metal substitution on the entire chassis will be allowed subject to the metal substitution rule.
10. Round is round, square is square, structural integrity must be maintained.
11. SKI SUSPENSION & STEERING
12. Ski suspension may be changed or altered but must remain stock appearing.
13. Ski widening devices are limited to three inches per ski leg.

SKIS & SKI RUNNERS

1. Aluminum OEM appearing skis for the model are allowed, provided the original spring concept remains the same.
2. Ski must maintain OEM length for the model.
3. Skis may be narrowed to within 1/8th inch of the structural bracing. The ski tip may be vented, structural integrity must be maintained.

TRACK SUSPENSION

1. Any 1988 or newer stock manufactured suspension be allowed that was on a production sled. Suspensions may be lightened or modified but must maintain structural integrity.
2. Commercially available suspensions are allowed (rev 2022)

TRACK & TRACTION

1. Any commercially available replacement rubber track is allowed.
2. The machine must be propelled by a single track. A minimum of 20 inches of track must be in contact with course surface when the machine is under a full power run.
3. Any new tracks or track systems must be certified by the ISR technical committee.
4. A minimum track width of 11.25 inches is allowed. (Must be OEM)

5. Drive wheels may be replaced by any commercially available drive wheel. Bulkhead may be modified but maintain structural integrity.

FRAME & BODY

1. Hood must appear to be 1988 or newer.
2. Hood must be completely stock appearing for the brand of the machine.
3. All hood openings may be covered with Plexiglas.
4. Belly pan must be OEM for the model, 1988 or newer.
5. The bottom of the belly pan and bulkhead, the width of the tunnel may be vented, but must retain structural integrity.
6. The bulkhead may be replaced with a commercially available aftermarket bulkhead.
7. Any insulation may be removed.
8. Windshield may be modified or removed.

IGNITION & ELECTRICAL

1. Any commercially available ignition allowed (Rev 2022).
2. Gauges may be removed and left open for venting.
3. Headlights may be removed and left open for venting.
4. Taillights may not be removed.

IMPROVED STOCK RULES

In stock and stock-based classes, no change or modification is allowed unless specifically allowed by these rules. If these rules do not specifically allow a change or modification, then it must be assumed that the change or modification is not allowed.

IMPROVED STOCK GENERAL RULES

1. Improved Stock classes may be offered at the promoter's option at any drag race.
2. Snowmobile must begin as a qualified stock snowmobile. All snowmobiles must comply with GENERAL RULES AND REGULATIONS SECTION.
3. Any alterations allowed in Stock are allowed in Improved Stock.
4. Snowmobile movement will be from Stock to Improved Stock.
5. Minimum combined weight is the weight of the snowmobile and the driver. NOTICE: Weights are reviewed annually.
6. Any snowmobile may be reclassified and reassigned in the interest of fair competition.
7. Improved Stock snowmobiles may advance to higher displacement class and not be required to meet the minimum weight for that higher class.
8. The snowmobile must have original OEM for the model engine, frame, suspension, fuel tank and seat. Named components must be OEM for the model and year, or properly filed OEM replacement parts that supersede the original OEM parts. Factory options are not allowed.

ENGINE

1. Engine components must be OEM for the model unless otherwise specified. May be modified internally, but engine must retain its complete external stock appearance and dimensions. Parts identification numbers must not be removed.
2. Cylinders must be OEM for the model. Must remain within OEM shell dimensions to include crevices, bulges, etc. No visible external changes allowed even if the area is hidden by another part or bracket. Number of cylinders must be OEM for the model. No external fastening devices allowed to secure or hold cylinders in place.
3. The cylinders may be raised to change port height. If a plate is used to raise cylinder height, the plate, including gaskets, cannot exceed 1/2 inch (0.50 inch) in thickness.
4. Engine may be bored up to class limit. A one percent (1%) overbore allowed. (EXAMPLE: 670cc engine may be bored up to 707cc's and may not be bored up to 800cc's to run in the 800cc class).
5. Crankshaft and crankcase must be OEM for the model. OEM stroke must be maintained. No modification allowed to the external surfaces of the crankcase even if the area is hidden by another part or bracket.
6. The cylinder head may be modified internally including changing replaceable combustion chambers and machining out combustion chambers to use replaceable inserts. The visible, outer portion of the cylinder head or cylinder head cover must remain stock appearing, and the spark plug must maintain OEM location.
7. Engine components allowable for modification or replacement.
 - Bearings
 - Rods (rod center to center must remain the same)
 - Pistons
 - Piston pins

Rings

Gaskets

8. Reeds and reed blocks may be changed, (external plate may be thicker) if they do not change the outside dimensions of the cylinder or crankcase.
9. No external modifications may be made to the crankcase or cylinder to accommodate reed block change.
10. Carburetors, flanges, and intake manifold must be OEM for the model. Internal modifications are allowed. Carburetor throat may be bored. Intake concept and location must remain OEM for the model.
On snowmobiles with OEM for the model Electronic Fuel Injection the throttle body, including the exterior, may be modified for increased fuel flow. No welding of the throttle body allowed (not even for repairs). Systems that allow increased fuel delivery may be used (i.e., Power Commander or others). The stock control module must be used. No changes for increased airflow allowed. Increasing the size of throttle body throat not allowed. OEM for the model throttle plate (butterfly) must be used without modification. **The Straightline Performance Kit** for 800 CC Ski Doo/BRP sleds, Part # 141-100 E-Tec Fuel Programmer and the **Speedwerx** Fuel Programmer are allowed for use in competition in the following Drag Race classes. Improved Stock ISR Bulletin 18/19-008
11. Except as noted, additional fuel delivery system or pressure charging is not allowed.
12. Internal and external modifications may be made to the airbox. The airbox may be removed. Air filters may be used.
13. Oil pumps may be removed or disabled. Oil tank must be removed. Oil injector nozzles may be removed and plugged. (If oil tank and overflow tank are joined the oil tank must be disabled or the joined tanks removed.)
14. Flywheel harmonic balancer may not be removed.
15. Torque arms allowed.
16. Rigid motor mounts allowed. OEM for the model engine location must be maintained. Replacing or adding metallic engine mounts is not allowed. Replacing rubber/cushion parts with more rigid parts is allowed.
17. Cooling systems must be operational. May contain disconnects for cool down. Heat exchangers may be relocated, modified, or removed.
18. Any functionally silenced exhaust system allowed. A commercially available, functionally silenced muffler/silencer must be installed and operational. (See General Snowmobile Requirements in Drag Racing for details.)
19. Exhaust outlet must exit body downward and rearward. (If OEM exhaust exits behind driver, pipe need not go downward). The minimum combined downward, rearward angle is 70° (from centerline of crankshaft). Exhaust pipe must not extend more than 3 in. beyond chassis or body.

DRIVE

1. Any primary and secondary clutch may be used.
2. Primary clutch and secondary clutch may be modified (no RPM limit).
3. Jackshafts, of like material and weight, may be changed to accommodate a clutch change. No welding allowed on a jackshaft. Steel and chrome moly allowed. Titanium not allowed unless OEM for the model. OEM location of shaft must be maintained.
4. Any track drive sprocket and non-driving wheels allowed on the track drive axle. Unless specified, no changes in drive, frame, or suspension allowed to accept track drive sprockets.
5. Track drive axle and chain case must remain OEM for the model and remain in OEM location.

SKI SUSPENSION & STEERING

1. Any aftermarket rear suspension shock may be used but must resemble the production shock in approximate overall body length, body diameter, and mounting eye overall length.
2. Ski stance must be OEM for the model.
3. Sled must have a minimum ride height of three (3) inches measured at the lowest point of the bulkhead/skid plate. Measurement points to be centered directly in front of the track drive area, (using the spindle centers to determine center point of bulkhead). **Functional suspension required.**

SKIS & SKI RUNNERS

1. Aftermarket skis allowed. Skis must be commercially available and marketed through normal sales activity. Minimum aftermarket ski length must be 40 inches. Ski width may not be trimmed. Skis may not be interchanged between brands. Lower ski surface must remain OEM.

TRACK SUSPENSION

1. OEM for the model suspension must be used. Suspension may be moved up and down in the tunnel (limit 3 inches, limited by the manufactures predrilled holes in the buck plate mount. OEM location must be maintained and may not protrude beyond tunnel configuration. Mechanical adjusters are allowed on the front torque arm only.
2. Functional suspension required.
3. Any aftermarket rear suspension shock may be used but must resemble the production shock in approximate overall body length, body diameter, and mounting eye overall length.
4. Any size, material, and number of rear axle idler wheels allowed. Unless specified, no modification to chassis or suspension allowed to accept idler wheels. Rear axle may be moved upward in the slide rails to accept larger rear idler wheels.
5. Commercially available long track kits allowed. Kit must be used in its entirety.
6. An approved tunnel enclosure must be added.

TRACK & TRACTION

1. Any commercially available one-piece molded rubber track allowed. Track must be race designated by the molder of the track. No cleated tracks allowed. Unless specified, no modification to drive, frame or suspension allowed to install track.
2. Commercially available long track rails and rail extensions allowed.
3. Track must remain untouched (no trimming).
4. Minimum lug height from the flat of the track is 0.50 inch, the maximum lug height of a replacement track is 1 1/2 inch.
5. 144" maximum track length

FRAME & BODY

1. Any chassis alterations, additions, or removals, which alter stock appearance or dimensions are not allowed. Tunnel can be repaired but must maintain OEM length.
2. Smaller fuel tanks may be used, but OEM type "shells" must contain the smaller tank. Tank must be securely fastened to the tunnel. Oil injection tanks may not be used as a fuel tank.
3. Removal of any insulation that alters the outside stock appearance is not allowed.
4. Any hood or side panels that maintain stock appearance (as defined) for the make and model may be used.

IGNITION & ELECTRICAL

1. **Any commercially available ignition allowed. (Complete)**
2. Tachometers, speedometers and/or heat gauges may be added or removed.
3. Open instrument holes must be closed.
4. Grass/ Ice / Snow, Electrical wires/wire harnesses and instrument drive cables may be removed.
5. Headlight assembly may be removed (opening must be closed). Headlight consoles are not considered part of headlight assembly.

Improved Stock 1000 Rules

GENERAL RULES

1. Minimum combined (driver and snowmobile) weight is seven hundred seventy-five (750) pounds, triple and four-cylinder engines.
2. Twin cylinder engines may weigh 685 pounds.

ENGINE

1. Any stock qualified model may be used, and the engine may be bored up to class limit. A one (2) percent over class cc allowed (1020 cc).
2. Rod center to center may be changed.
3. Stroke may be changed.
4. Crankshaft may be modified or replaced.
5. Crankshaft gears may be changed.
6. Cylinders may be modified internally and externally. Cylinders may be replaced with aftermarket cylinders.
7. Cylinders may not be interchanged between brands. Welding on crankcase is not an acceptable method to adapt aftermarket or other OEM cylinders to crankcase.
8. Any commercially available head allowed.
9. Intake concept and location must remain OEM for the model.
10. The reed valve mounting area on the crankcase may be modified to change reed angle. The upper surface of the intake tract may be reinforced by welding or bonding.
11. More than one OEM type fuel pump allowed.
12. In Improved Stock 1000, 2-cylinder, 3 cylinder, -2 stroke engines carburetors, mounting spigots and air boots may be modified or replaced. Flange can be modified internally.
13. Improved Stock 1000 four stroke engines must compete in stock trim.
14. Airbox may be removed.

TRACK & TRACTION

1. Commercially available long track kits allowed. Kit must be used in its entirety.

IGNITION & ELECTRICAL

1. Any ignition may be used. Electrical stutter boxes launch control and traction control allowed.

PRO STOCK

PRO STOCK CLASSES AND RULES

In stock and stock-based classes, no change or modification is allowed unless specifically allowed by these rules. If these rules do not specifically allow a change or modification, then it must be assumed that the change or modification is not allowed. **Pro stock classes are frozen for a period of two years. The next year for any rule changes except safety items will be 2025. Effective 4-21-2022**

PRO STOCK GENERAL RULES

1. Pro Stock snowmobiles must originate as ISR stock qualified snowmobiles.
2. OEM serial numbers are not required, but engine and frame must have unique identification numbers that identify the OEM model and year. (See #4 below.)
3. The OEM for the model frame, and engine, must be used. Unless otherwise specified, all parts and components including the hood, seat, engine, drive, and chassis must retain OEM stock appearance for the model.
4. The OEM for the model frame including bulkhead and tunnel must be used as structural members to mount the engine, drive components and suspension. Tunnel may be repaired or replaced.
5. An OEM for the brand "like chassis" may be substituted for the OEM chassis. "Like chassis" must have the same front suspension concept as the original chassis (i.e., trailing arm, "A" arm, or strut). When engine is installed in the "like chassis," the crankshaft must be in the OEM location for the chassis. The engine installation must conform to the engine location rules.
6. Any snowmobile may be reclassified in the interest of fair competition.
7. Snowmobile must comply with GENERAL RULES AND REGULATIONS SECTION.
8. Any alterations allowed in Stock and Improved Stock classes are also allowed.

ENGINE

1. Crankcase, cylinders, and crankshaft must be from the same stock qualified model. Must retain original number of cylinders.
2. Crankcase may be modified internally provided the engine retains its complete external stock appearance and dimensions except as noted in these rules.
3. The only external modification allowed to the crankcase is to the cylinder mounting surface and must be covered by the OEM for the engine cylinder base gasket.
4. Crankshaft may be changed.
5. Crankshaft may be modified.
6. Stroke may be changed. Connecting rod length may be changed.
7. Four-cylinder crankshaft gears may be changed with any OEM crankshaft gear.
8. Cylinders must be OEM for the model and mounted in OEM location and orientation.
9. Cylinder may be modified internally provided the engine retains its complete external stock appearance and dimensions except as noted in these rules.
10. Cylinder overbore is limited to a 2% increase in displacement over the cc limit for the class.
11. Cylinder may be bored up or sleeved down.
12. OEM cylinder outer shell dimensions' modification must be within .020 inches (1/2mm) per side/.040 inches (1mm) overall of the OEM cylinder dimensions. Modification must be blended into original casting to retain OEM appearance.
13. Cylinder height may be modified to change port height. If a plate is used to raise cylinder height, the plate, including gaskets, cannot exceed 1/2 (.500) inch.
14. Any commercially available cylinder head allowed. Cylinder head may be replaced with aftermarket billet or cast. The OEM cylinder head may be modified internally including changing replaceable combustion chambers and machining out combustion chambers to use replaceable inserts.
15. Any carburetor may be used. Only one venturi allowed per cylinder.
16. Intake concept and location must remain OEM for the model.
17. Fuel injection allowed.
18. No turbo-chargers, super-chargers or nitrous allowed.
19. Intake concept and location must remain OEM for the model engine with the exception that EFI models may be changed to carburetor induction.
20. Reeds and reed cage may be replaced or modified so long as the outside dimensions of the cylinder or crankcase are not compromised. External plate may be thicker. No welding or bonding to cylinder or crankcase to accommodate reed assembly allowed. Reed assembly changes must be accomplished by bolting only.
21. Other engine components allowable for modification or replacement:
 - Bearings

Rods
Pistons, pins, and rings
Gaskets
Bolt-on intake and exhaust flanges
Fuel pump
Engine mounts
Airboxes may be removed.

22. Engine must retain original cooling concept. (Liquid, fan, or free-air cooling must be retained but cooling circuits can be modified or removed.)
23. Water pumps may be removed.
24. Radiators and ducting may be used but must not change OEM appearance. Radiator must not protrude beyond the belly pan and must be within 1/4 inch of the belly pan. Maximum opening in belly pan is one hundred (100) square inches. Radiator must be functional.
25. Any functionally silenced exhaust system allowed. Exhaust outlet must not protrude more than three (3) inches beyond the chassis or hood configuration. A commercially available, functionally silenced muffler/silencer must be installed and operational. (See General Snowmobile Requirements)
26. Exhaust outlet must exit body downward and rearward. (If OEM exhaust exits behind driver, pipe need not go downward). The minimum combined downward, rearward angle is 70° (from centerline of crankshaft). Exhaust pipe must not extend more than 3 in. beyond chassis or body.

DRIVE

1. Any primary or secondary clutch may be used.
2. Clutch jackshaft may be changed or modified (no welding on jackshaft).
3. Relocation of crankshaft, jackshaft, drive shaft (front drive axle) allowed.
 - a. Crankshaft may be moved up or down, forward, or backward if engine and primary and secondary clutch is within confines of the hood, console, and side panels and front close off panel on the bulkhead.
 - b. No altering of bulkhead for engine movement other than the engine mounts or engine plate to hold engine.
 - c. Crankshaft to jackshaft center to center is allowed +/- 1" (one inch) tolerance from OEM specification for the model.
 - d. Chain case may be moved anywhere on side of bulkhead or tunnel however jackshaft must remain on top of tunnel or front side of bulkhead. Left side drive axle bearing, bearing carrier, and bolts may not be below tunnel or bulkhead side.
 - e. Any OEM or aftermarket chain case allowed.
 - f. Jackshaft to rear axle of suspension center to center distance measurement may not exceed sixty-four (64) inches measured in a parallel line with and adjacent to the top of tunnel. For (Ski Doo XP, XM, XS)(Polaris Axis, Matrix) chassis sixty-eight (68) inches measured in a parallel line with and adjacent to the top of tunnel. Other chassis will be evaluated for non-conformance to the 64" rule. Maximum track length is 144" inches. (Clarification 4-21-22)
Any track drive sprocket and non-driving wheels allowed on the track drive axle. Unless specified, no changes in drive, frame, or suspension allowed to accept track drive sprockets.
4. Drive reduction system must be OEM for the model concept (i.e., chain, belt, or gear). Chain case / gear case and cover may be from any stock qualified model within the brand.
5. Chain case / gear case modification is not allowed. Chain case / gear case must be functionally driving the snowmobile with the OEM for the model drive concept (i.e., chain, belt, or gear).
6. Any chain, belt, sprockets, and gears allowed for drive reduction system.
7. Brake assembly may be on either the jackshaft or the track drive axle.
8. Brake caliper may be either dual opposing piston or single piston type.
9. Minimum brake disk diameter is 7.0 inches. (If brake disk is mounted to track drive axle and a dual opposing piston caliper is used, the disk minimum diameter is 6 inches.)
10. Pro Stock qualified snowmobiles need not comply with Modified brake requirements when jumping up into Modified classes.

SKI SUSPENSION & STEERING

1. Front suspension components including struts, arms, spindles, rod ends, spherical joints, tie rods, linkages, IFS trailing arms and radius rods must remain OEM design concept but may be changed in shape and appearance. All must remain in the OEM location on the chassis.
2. Sway bar and links may be removed. If sway bar is disconnected, it must be removed.
3. Functional suspension required.
4. Material substitution is allowed. Replaced components must be as strong or stronger than OEM components.
5. Shock absorbers may be replaced. Any commercially available, hydraulically or air damped shocks may be used. Shocks must remain in a location + or - 3 inches from original OEM location.
6. Spindles may be strengthened or replaced with a stronger spindle. Spindle height must remain within 10% of the original OEM dimensions.
7. Minimum ski stance (center to center of the ski runners) is 38 inches.
8. Ski widening devices allowed. No maximum ski stance width.
9. Handlebars, handlebar grips and controls may be modified or changed.

SKIS AND SKI RUNNERS

1. Any commercially available OEM appearing, or aftermarket ski may be used provided the original spring concept remains the same.
2. Minimum ski length is twenty (20) inches.

TRACK SUSPENSION

1. Any track suspension allowed that can be installed within the confines of the tunnel.
2. Material substitution is allowed. Replaced components must be as strong or stronger than OEM components.
3. Shock absorbers may be replaced. Only commercially available, hydraulically or air damped shocks specified for use on a snowmobile are allowed.
4. Outboard mounted shocks do not compromise OEM stock appearance.
5. Functional suspension required.

TRACK & TRACTION

1. Any commercially available one-piece molded rubber track allowed. Track must be race designated by the molder of the track. No cleated tracks allowed.
2. Track and track suspension must fit within the confines of the tunnel.
3. Track lug height may be trimmed to a minimum of ½ inch lug height. No other track trimming allowed.
4. Holes for traction products must be a minimum distance of 5/8 inch from track edge or any other hole or opening in the track. A maximum of 2 holes allowed in each track segment outside of each slide rail. A maximum of 4 holes allowed in each track segment inside the slide rails. (A total of 8 holes per track segment.)

FRAME AND BODY

1. The OEM for the model frame including bulkhead and tunnel must be used as structural members to mount the engine, drive components and suspension components. Tunnel may be repaired or replaced.
2. Chassis reinforcement allowed. No lightening holes can be drilled that alter the outside appearance for the model.
3. Structural integrity must be maintained. Replaced components must be as strong or stronger than OEM components. The Race / Tech Director shall have the authority to determine structural integrity.
4. Access openings for component accessibility will be allowed, but must be closed with original type materials, i.e., hinged clutch covers.
5. Snowmobiles using production or aftermarket tunnels that measure less than 1/8 or .125 inch in thickness shall have ONE of the following:
 - A. Additional sheet or sheets of metal to the tunnel to achieve .125 thickness. The sheet metal shall be the same width as the tunnel and shall extend from the rear of the tunnel to the horizontal centerline of the track drive axle. Tunnels 1/8-inch (.125) thick or thicker do not require this added sheet provided that the 1/8-inch (.125) tunnel extends to the horizontal centerline of the track drive axle.
 - B. Two (2) tunnel protectors permanently fastened to the inside of the tunnel. Tunnel protectors must be minimum 1.500 inch tall (height) and may be either rectangular aluminum tube or machined aluminum. The tunnel protectors shall extend from the rear of the tunnel to the horizontal centerline of the track drive axle.Tunnels that are 1/8-inch (.125) thick or thicker do not require additional protection.
6. Hood to belly pan molding must remain intact. The molding may be lightened if it does not alter the outside OEM appearance.
7. Seat must remain in OEM contour and be stock appearing. Seat may be lowered equally front to rear but must be at least six (6) inches thick (or OEM height if less than 6 inches) at its minimum dimension (seat height will be measured from the top of original tunnel to top of seat in rider less state). Measurements will be made at the lowest point of the seat. The rigid console cover may be lowered to blend into seat contour. Seat must maintain 24 inches of contact with the tunnel.
Aftermarket seats may be used that conform to the above stated rules concerning OEM seat. No fiberglass or carbon fiber seats, seat must be of conventional style (padding and upholstery) and commercially available.
8. The outside gas tank shell must remain intact and in its OEM location. The fuel tank may be modified to accommodate a fuel cell. The fuel cap may be replaced with the fuel cell cap. All fuel must be contained in the OEM for the model fuel tank location. The use of a fuel cell used within the above rule will not compromise OEM appearance.
9. Front air dams allowed. Must be a minimum of 2 inches above the ground with front suspension totally compressed.
10. Except for front air dam (which requires 2" inch clearance), all other parts and components must maintain a minimum of 1" inch ground clearance with the suspension fully compressed.

IGNITION AND ELECTRICAL

1. Any ignition may be used. Electrical stutter boxes launch control and traction control allowed.
2. External electric starters are legal.
3. Any instrumentation allowed. Tachometer, speedometer, or heat gauges may be added or removed. Open instrument holes must be closed.
4. Electrical wiring may be removed.
5. Headlight assembly may be removed (opening must be closed). Headlight consoles are not considered part of headlight assembly.

PRO STOCK 1000

ENGINE

1. Aftermarket cylinders for the brand are allowed.
2. Cylinders must be commercially available.
3. Cylinders may not be interchanged between brands. Welding or bonding on a crankcase is not an acceptable method to adapt aftermarket cylinders.
4. Any commercially available cylinder head allowed.
5. The reed valve mounting area on the crankcase may be modified to change reed angle. The upper surface of the intake tract may be reinforced by welding or bonding.

IGNITION & ELECTRICAL

1. Any ignition may be used. Electrical stutter boxes launch control and traction control allowed.
2. External electric starters are legal.

ENGINE

1. The engine must be from a stock -qualified snowmobile. The rules committee will approve the validity of all engines. Watercraft crankcase and crankshaft from a snowmobile manufacturer may be used.
2. There is a 2000 maximum c.c. limit on total engine volume.
3. One power adder, allowed. Supercharging, turbo charging, or nitrous oxide systems are allowed, but may not be combined. Example, if a competitor adds a turbocharger to an engine, he may not also add a nitrous system.
4. Fuel injection systems are allowed.
5. Turbo Exhaust must be constructed in a manner that the exhaust outlet is not directed at the driver or competitor.
6. Maximum turbo inducer size is 55mm.
7. Exhaust system must fit within overall maximum length and width rules.
8. This is a gasoline only class.

DRIVE

1. Any CVT type primary and secondary clutch may be used.
2. Primary clutch and secondary clutch may be modified (no RPM limit)
3. Clutch cover must have full facial coverage and 360-degree elliptical coverage in the direction of clutch/belt travel (see illustration). Clutch cover must be .090-inch 6061T6 aluminum or equivalent steel material and be covered with six (6) inch belting. Other clutch cover materials not allowed. If the clutch cover is fastened to the existing belly pan, the area below the clutches (from front of cover to rear of cover and width of cover) must be covered with .090-inch 6061T6 aluminum or equivalent. If cover is .125 inch, 6061T6 aluminum or equivalent steel material, belting is recommended, but not mandatory. Clutch cover and related belting must be securely fastened.

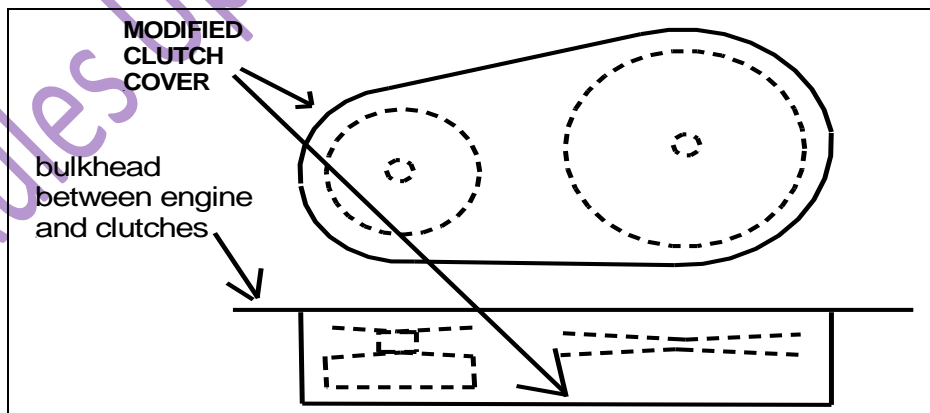

4. Backside of clutches must be covered by a portion of the clutch cover or by a bulkhead of comparable material.
5. Pro Extreme 55 class sleds must have a twin opposed piston caliper braking system with a minimum 3/16 (.015-inch tolerance) inch thick, 6.0-inch minimum diameter brake disc, mounted on the drive axle. Any manufactured brake disc allowed, except no aluminum brake disc may be used.

SKI SUSPENSION AND STEERING

1. The front suspension must remain OEM design concept but may be changed in shape and appearance.
2. Material substitution is allowed. Replaced components acceptability for construction and strength will be at the discretion of the Technical Inspector. Inspection holes may be required to be bored into components at any time by Technical Inspectors. Technical Inspectors decision regarding acceptability is final. New, novel, or controversial designs are strongly suggested to be presented to technical approval, during the construction process for review. Construction concepts will remain proprietary to the builder but may be forwarded to select SMDG members with expertise in the area for advisory input.

SKIS & SKI RUNNERS

1. Any commercially available OEM appearing, or aftermarket ski may be used provided the original spring concept remains the same.
2. Minimum ski length is twenty (20) inches.
3. Must be a minimum ride height of three (3) inches measured at the lowest point of the bulkhead/skid plate. Measurement point to be centered directly in front of the track drive area, (using the spindle centers to determine center point of bulkhead) and must retain 2 inches of remaining compression travel with driver on snowmobile.

TRACK SUSPENSION

1. Must be a minimum of 2 inches of remaining compression travel with driver on snowmobile.

TRACK & TRACTION

1. Any commercially available one-piece molded rubber track allowed. Track must be race designated by the molder of the track. No clefted tracks allowed.
2. Speed tracks and suspensions will be allowed.
3. Track lug height may be trimmed to a minimum of ½ inch lug height. No other track trimming allowed.
4. Minimum track width is 13.5 inches.
5. Any traction device must not extend more than ¾ inch, (.750 inch) above the highest point of the track or traction lug.

FRAME & BODY

1. Snowmobile must resemble a stock model and profile. Minimum handlebar height 30" inches from ground to center of tube.
 2. Aftermarket body panels and approved duplications of production bodies of any material will be permitted if OEM appearance for the declared model and brand is maintained. The hood and belly pan may be removable. One-piece hood with side panels and or air dams molded in are allowed. Hood must have top and side cowling and must contain at least one thousand three hundred (1300) square inches.
 3. Front air dams allowed. Must be a minimum of 2 inches above the ground with front suspension fully compressed.
 4. Windshields are required.
 5. No additional bodywork that changes stock appearance allowed.
 6. Ventilation openings may be covered.
 7. Suspension side skirts are prohibited.
 8. Aerodynamic devices, airfoils, and wings are prohibited.
 9. Openings for component accessibility are allowed.
 10. Cowl, or gas tank area must blend into seat.
 11. Seats other than OEM stock, are allowed. Stock seats may be cut down for lower profile. All seats must be a minimum of 2" in thickness.
 12. Commercially available aftermarket and custom frames are allowed. Design and structural integrity are subject to technical inspection for safety and compliance to general rules section.
 13. All aftermarket and custom frame components except braces, brackets, and gussets must be manufactured from 4130 chrome moly tubing and plate or 7075, 6061, aluminum plate. Use of stock OEM bulkhead allowed, and reinforcement of same is allowed.
 14. Stock tunnels may be used with any commercially available aftermarket or custom front end.
 15. Motor mounts and jackshafts may be changed from original location.
 16. Snowmobiles using production or aftermarket tunnels that measure less than 1/8 or .125 inch in thickness shall have ONE of the following:
 - A. Additional sheet or sheets of metal to the tunnel to achieve .125 thickness. The sheet metal shall be the same width as the tunnel and shall extend from the rear of the tunnel to the horizontal centerline of the track drive axle. Tunnels 1/8-inch (.125) thick or thicker do not require this added sheet provided that the 1/8-inch (.125) tunnel extends to the horizontal centerline of the track drive axle.
- OR
- B. Two (2) tunnel protectors permanently fastened to the inside of the tunnel. Tunnel protectors must be minimum 1.500 inch tall (height) and may be either rectangular aluminum tube or machined aluminum. The tunnel protectors shall extend from the rear of the tunnel to the horizontal centerline of the track drive axle.
- Tunnels that are 1/8-inch (.125) thick or thicker do not require additional protection.

IGNITION & ELECTRICAL

1. Any ignition may be used. Electrical stutter boxes launch control and traction control allowed.
2. External electric starters are legal.

UPDATED FOR THE REMAINDER OF THE 2024 SEASON^{02/07/24}

SPEED RUN PRO MOD CLASSES AND RULES

PRO MOD WEIGHTS

PRO MOD

Max cc Grass Ice Snow

Pro Mod 500 2 cyl 500 550 550 N/A

Pro Mod 600 2 cyl 600 550 550 N/A

Pro Mod 600 3 cyl 600 600 600 N/A

Pro Mod 700 2 cyl 700 550 550 N/A

Pro Mod 700 3 cyl 700 625 625 N/A

Pro Mod 800 2 cyl 800 550 550 N/A

Pro Mod 800 3 cyl 800 625 625 N/A

Pro Mod 900 2 cyl 900 550 550 N/A

Pro Mod 900 3 cyl 900 625 625 N/A

Pro Mod 1000cc 2 cyl 1025 530 530 572

Pro Mod 1000cc 3 cyl 1050 585 585 650

Pro Mod 1000cc 4 cyl 1050 625 625 695

MINIMUM COMBINED WEIGHT IS THE WEIGHT OF THE SNOWMOBILE AND DRIVER. Weight may be adjusted at any time in the interest of fair competition.

GENERAL SNOWMOBILE RULES

1. All snowmobiles competing in the Pro Mod class must comply with GENERAL RULES AND REGULATIONS SECTION.
2. Race Director shall have the authority to determine structural integrity.
3. Engine and chassis may be interchanged between brands.
4. Race vehicles advancing to the next class must meet all the safety requirements of the advanced class.

ENGINE

1. The engine must have been OEM manufactured for snowmobile use for 600, 700, 800cc classes.
2. Aftermarket cylinders and crankcases and heads are allowed.
3. Cylinder maximum overbore is limited to two (2) percent over the cc displacement for the class.
4. Cylinder, crankcase, crankshaft, and heads may be interchanged within the brands.
5. Welding on the crankcase or cylinders is allowed.
6. Any carburetor or fuel injection may be used. Only one venturi allowed per cylinder.
7. EFI models may be changed to carburetor induction.
8. Exhaust systems cannot compromise/exceed overall snowmobile length and width.
9. Exhaust stinger must be directed downward and rearward.
10. Exhaust system must be functionally silenced. (See General Snowmobile Requirements in Drag Racing for details.)
11. Exhaust system must fit within overall maximum length and width rules.

IGNITION AND ELECTRICAL

7. Any ignition may be used. Electrical stutter boxes launch control and traction control allowed.
8. External electric starters are legal.
9. Any instrumentation allowed.

SKI SUSPENSION AND STEERING

1. **Sled must have a minimum ride height of two (2) inches measured at the lowest point of the bulkhead/skid plate is using solid strut links, 3 inches if using functioning shock absorbers as suspension links.** Measurement points to be centered directly in front of the track drive area, (using the spindle centers to determine center point of bulkhead) ~~Functional suspension required.~~ **Constructor may use solid struts or purpose-built shock absorbers of Hydraulic, Air, Gas, or Magnetic/Electronic design.**
2. Stock spindles may be reinforced or replaced. Replacement spindles must have a minimum wall thickness of .120 inch and minimum outside diameter of .750 inch. An inspection hole is required if wall thickness is not visible.
3. If modifications to suspension parts are made, structural integrity must be maintained.
4. Minimum ski stance (center to center of the ski runners) is 38 inches.

SKIS & SKI RUNNERS

1. Any commercially available ~~OEM appearing~~, or aftermarket ski may be used. ~~provided the original spring concept remains the same.~~
2. Minimum ski length is 17.5 inches. (Clarification)

TRACK SUSPENSION

1. Any aftermarket or OEM suspension is allowed. Modifications to OEM or any commercially available aftermarket suspensions must maintain structural integrity.
2. Functional suspension required.

TRACK & TRACTION

1. Any commercially available one-piece molded rubber track allowed. Track must be race designated by the molder of the track. No cleated tracks allowed.
2. Track lug height may be trimmed to a minimum of ½ inch lug height. No other track trimming allowed.
3. Minimum track width is 13.5 inches.
4. 159" maximum track length

FRAME & BODY

1. ~~Snowmobile~~ Must resemble a stock model and a snowmobile in profile view. Minimum handlebar height 30" inches from ground to center of tube.
2. The hood and belly pan may be removable. ~~if OEM appearance for the declared model and brand is maintained.~~ One-piece hood with side panels and or air dams molded in are allowed.
3. Front air dams allowed. Must be a minimum of 2 inches above the ground with front suspension fully compressed. (For sleds with functioning front suspension) For sleds with solid strut style front links the minimum is also 2 inches above the ground.
4. Aftermarket body panels and approved duplications of production bodies of any material will be permitted.
5. Windshields are required.
6. ~~No additional bodywork that changes stock appearance allowed.~~
7. Ventilation openings may be covered.
8. Suspension side skirts are prohibited.
9. ~~Aerodynamic devices, airfoils, and wings are prohibited.~~
10. Openings for component accessibility are allowed.
11. Cow, or gas tank area must blend into seat.
12. ~~All seats must be a minimum 2" thick. (Seat and frame work). Seat must maintain 24 inches of contact with the tunnel Seats other than OEM stock, are allowed, but must resemble production based seats. Seat should be stock appearing with driver off the sled. Seats, seat pads, or cushions allowed.~~
13. Commercially available aftermarket and custom frames are allowed. Design and structural integrity are subject to technical inspection for safety and compliance to general rules section.
14. All aftermarket and custom frame components except braces, brackets, and gussets must be manufactured from 4130 chrome moly tubing and plate or 7075, 6061, aluminum plate. Use of stock OEM bulkhead allowed, and reinforcement of same is allowed.
15. Stock tunnels may be used with any commercially available aftermarket or custom front end.
16. Motor mounts and jackshafts may be changed from original location.
17. Any engine location is allowed if stock snowmobile profile is maintained.
18. Snowmobiles using production or aftermarket tunnels that measure less than 1/8 or .125 inch in thickness shall have ONE of the following:
 - A. Additional sheet or sheets of metal to the tunnel to achieve .125 thickness. The sheet metal shall be the same width as the tunnel and shall extend from the rear of the tunnel to the horizontal centerline of the track drive axle. Tunnels 1/8-inch (.125) thick or thicker do not require this added sheet provided that the 1/8-inch (.125) tunnel extends to the horizontal centerline of the track drive axle.OR
 - B. Two (2) tunnel protectors permanently fastened to the inside of the tunnel. Tunnel protectors must be minimum 1.500 inch tall (height) and may be either rectangular aluminum tube or machined aluminum. The tunnel protectors shall extend from the rear of the tunnel to the horizontal centerline of the track drive axle. Tunnels that are 1/8-inch (.125) thick or thicker do not require additional protection.

DRIVE

1. The clutch cover must be separate of the cowl configuration and cover the clutch perimeter and faces to the center of the clutch bolt or below.
Must be .090 inch 6061 T6 aluminum or equivalent steel material the outer perimeter must be covered with 6-inch belting. No other clutch cover material is allowed. If 0.125-inch aluminum or steel is used, belting is recommended but not required. Snowmobiles with removable side panels may fasten clutch covers/ shields to side panels to meet this requirement.

BRAKES

1. Brake assembly may be on either the jackshaft or the track drive axle.
2. Brake caliper may be either dual opposing piston or single piston type.
3. Brake disc must be a minimum of 3/16" inch thick (.015-inch tolerance), 6" inch diameter and be dual opposing piston if on the drive axle. 7" if on the jackshaft.
4. Steel manufactured brake disc allowed only. No Aluminum, Titanium, or Carbon fiber allowed.
5. Braided steel brake lines are mandatory.
6. Brake drive shaft system located outside of tunnel must be enclosed and shielded.

IGNITION & ELECTRICAL

1. Any ignition may be used. Electrical stutter boxes launch control and traction control allowed.
2. External electric starters are legal

Notification: The above amended rules also apply to Pro-55 and Pro Xtreme.

Additional update:

In NSSR Speed run rules, Pro Extreme 55 – Four Stroke

NSSR will allow a minimum track width of 10.5 inches and track to be narrowed by approved method of water jetting or vendor such as Tracks USA.

OPEN MODIFIED RULES

GENERAL

1. Competition is open to any snowmobile, either production or one of a kind experimental (which could include rear engine type snowmobiles).
2. Minimum wet weight (without gas) is two hundred fifty (250) pounds.
3. 800cc and 1000 cc - maximum overall length 144 inches.
4. All snowmobiles competing in Open Modified Class must comply with GENERAL RULES AND REGULATIONS SECTION.
5. The Race Director shall have the authority to determine structural integrity.

ENGINE

6. The engine must have been manufactured for snowmobile use (this does not include outboard, motorcycle, aircraft, or automotive engines). The Race Rules Committee will approve the validity of all engines.
7. Cylinder maximum overbore is defined as two (2) percent over the cc displacement for the class. Open modified 1000 maximum overbore is defined as five (5%) percent over the cc displacement for the class.
8. Fuel injection allowed.
9. Exhaust not enclosed within the confines of the cowl must point rearward, downward and extend rearward beyond front cross member/spindle centerline. Exhaust systems cannot compromise/exceed overall snowmobile length and width. Exhaust stinger must be directed downward and rearward. Exhaust system must be functionally silenced.

DRIVE

1. Modified 800cc classes and above must have a twin opposed piston caliper braking system with a minimum 3/16 (.015-inch tolerance) inch thick, six (6) inch minimum diameter brake disc, mounted on the drive axle. Any manufactured brake disc may be milled or drilled in the original pad contact area (all pads inclusive). The disc pad contact area may not be reduced more than 15% of the original pad contact area.
2. No carbon fiber drive wheels or non-driving wheels allowed.

SKI SUSPENSION AND STEERING

1. Dual limiter straps required. A minimum of 1.0 inches of compression suspension travel must remain with the driver seated on the snowmobile.

SKIS & SKI RUNNERS

1. Any OEM appearing ski may be used provided the original spring concept remains the same.
2. It is highly recommended, if a cutting edge is used on a ski, that no more than five (5) inches of ninety (90) degree cutting edge be used on a ski.

3. Maximum overall width is 45 inches. When a stock snowmobile, wider than 45 inches, moves into a Modified class, the width must be reduced. If a stock ski is trimmed to meet the forty-five (45) inch rule, the ski can be trimmed only to forty-five (45) inches.
4. Ski loop must be designed to prohibit ski interlock with any other component while driver is on the snowmobile.

TRACK & TRACTION

1. Snowmobile must maintain twenty (20) linear inches of track length on the course surface when the snowmobile is under full power.
2. Except for under slide rails, all plates must be no larger than two and one quarter (2 1/4) inches in width and length. Kicker plate must be located under slide rail and be no longer than 3 1/4 inches and no wider than 1 1/4 inches.

TRACK SUSPENSION

1. No carbon fiber slide rails allowed.

FRAME & BODY

1. Snowmobiles using production or aftermarket tunnels that measure less than 1/8 or .125 inch in thickness shall have ONE of the following:
 - A. Additional sheet or sheets of metal to the tunnel to achieve .125 thickness. The sheet metal shall be the same width as the tunnel and shall extend from the rear of the tunnel to the horizontal centerline of the track drive axle. Tunnels 1/8-inch (.125) thick or thicker do not require this added sheet provided that the 1/8-inch (.125) tunnel extends to the horizontal centerline of the track drive axle.
- OR
- B. Two (2) tunnel protectors permanently fastened to the inside of the tunnel. Tunnel protectors must be minimum 1.500 inch tall (height) and may be either rectangular aluminum tube or machined aluminum. The tunnel protectors shall extend from the rear of the tunnel to the horizontal centerline of the track drive axle.
Tunnels that are 1/8-inch (.125) thick or thicker do not require additional protection.

DIAL IN CLASSES

GENERAL

1. There is one Dial-In class. There will be safety inspection only, no tech inspection.
2. Snowmobiles must comply with the GENERAL RULES AND REGULATIONS section.
3. Competition is open to any snowmobile meeting all safety related rules. There are no restrictions as to the type or age of the snowmobile. Participants must select the speed they wish to dial-in for the day (this must be accomplished prior to the start of the event).

ENGINE

1. Any snowmobile engine is allowed with a maximum of 1100cc's.
2. Any functionally silenced exhaust allowed. Exhaust emission pipe must not protrude more than three (3) inches beyond the chassis or hood configuration.

DRIVE

1. Any variable ratio belt driven clutch allowed.
2. If brakes are altered, they must pass technical safety inspection to enter in the event.
3. No carbon fiber drive wheels or non-driving wheels allowed.

TRACK & TRACTION

1. The snowmobile must be propelled by a single track. The continuous track length is to run parallel to the snowmobile length and maintain 20 inches in length of continuous surface traction on the course surface. Track surface must be in contact with the course surface when the snowmobile is under a full power run.
2. A minimum track width of 11 1/4 inches, a 1/8-inch minimum variance in the minimum track width requirement is allowed.
3. The track must be confined in the tunnel and extend to within six (6) inches of the rear of the tunnel.
4. Any new tracks or track system must be certified by the ISR Technical Committee.

TRACK SUSPENSION

1. No carbon fiber slide rails allowed.

FRAME & BODY

1. Chassis, bulkhead, and tunnel must maintain structural integrity. Tech officials have the final say as to the structural integrity of the snowmobile.

IGNITION & ELECTRICAL

1. Instrument pods may be removed.

LAKE RACER**GENERAL**

1. There is one (1) Lake Racer class for stock bodied snowmobiles limited to 1050cc engines.
2. Snowmobile with stock track and suspension will have a limit of 125.036 mph and snowmobiles with a speed track and suspension will have a limit of 130.120 mph for break out points.
3. Minimum combined weight (driver and snowmobile) is 750 lbs.
4. Gasoline, alcohol and nitrous are allowed.
5. All snowmobiles competing in the Lake Racer class must comply with applicable rules in the GENERAL RULES & REGULATIONS section.

ENGINE

1. The engine and engine components must have been manufactured for snowmobile use unless otherwise specified by the class rules. (Outboard, motorcycle, aircraft, ATV, watercraft, or automotive engine components are not allowed). The race rules committee will approve all engines. The engine must appear to be a snowmobile engine.
2. Engine must be 1988 or newer. Engine must retain original cooling concept (liquid, fan, or free air cooling), but cooling circuits can be modified or removed.
3. Any 1988 or newer OEM crankcase and crankshaft for the brand is allowed.
4. Cylinders-Any 1988 or newer OEM cylinders and heads allowed. Aftermarket snowmobile cylinders and heads allowed.
5. Engine components allowable for modifications or replacement:
 - Airboxes may be modified, replaced, or removed.
 - Bearings
 - Carburetors-A maximum of one (1) venturi or one (1) throttle body per cylinder is allowed.
 - Cylinders
 - Fuel pump
 - Gaskets
 - Heads
 - Ignition
 - Manifolds (intake)
 - Motor mounts
 - Oil pump
 - Pistons, pins, and rings
 - Rods-OEM stroke must remain the same.
 - Water pump
6. Any fuel injection system is allowed.
7. Any functionally silenced exhaust allowed. Exhaust emission pipe must not protrude more than three (3) inches beyond the chassis or hood configuration.

DRIVE

1. The snowmobile must be propelled by a variable ratio transmission. **Direct Drive development project is ongoing.**
2. Jackshaft may be changed or modified: subject to metal substitution rule (no welding on jackshaft).
3. Chain case must remain OEM for the model.
4. Any steel replacement gears are allowed.
5. The chain must be completely enclosed on the sides and top, (the bottom may be left open), with a minimum of 1/16 inch 6061T6 aluminum. A maximum of two (2) lubrication holes (maximum 3/4-inch diameter each) may be drilled in the approximate location of the sprockets on the outboard side of the case.
6. Brakes may be changed or altered but must be always operational. Liquid cooling systems allowed. Master cylinder and caliper assembly must be commercially available.
7. All snowmobiles 800 cc and above must have twin opposed piston caliper braking system with a minimum 3/16 (.015-inch tolerance) inch thick, six (6) inch minimum diameter brake disc. Any manufactured brake disc may be milled or drilled in the original pad contact area (all pads inclusive). The disc pad contact surface area must not be reduced by more than 15% original pad contact surface area.

8. No carbon fiber drive wheels or non-driving wheels allowed.
- 9.

SKI SUSPENSION & STEERING

1. Ski suspension must remain OEM appearing for the model. Material substitution is allowed. Ski widening devices limited to 45 inch maximum. Spindles may be strengthened or replaced with a stronger spindle.
2. Lake Racers must have two (2) inches travel in usable ski suspension.
3. Snowmobile must have a windshield. Any windshield allowed.
4. Snowmobile must have a hood and belly pan.
5. Handlebars, handlebar grips and controls may be modified.

SKIS & SKI RUNNERS

1. Any OEM appearing ski may be used provided the original spring concept remains the same. (Plastic, aluminum, or steel).
2. Ski concept and appearance for the model must be maintained.
3. Aftermarket plastic, metal or aluminum skis allowed.

TRACK SUSPENSION

1. Track suspension may be moved up and down in the tunnel (limit 3 inches). OEM location must be maintained and may not protrude beyond tunnel configuration.
2. Rails may be bent. Linkages may be changed. OEM suspension wheel diameters may be added or changed. Suspension wheel diameters may be trued. All suspension wheels must be within the confines of the track.
3. Shocks may be changed. Outboard shocks must remain outboard. Inboard shocks must remain inboard.
4. Lake Racers must have two (2) inches travel in useable track suspension.
5. Any suspension is allowed with speed tracks.

TRACK & TRACTION

1. The snowmobile must be propelled by a single track. The continuous track length is to run parallel to the snowmobile length and maintain twenty (20) inches in length of continuous surface traction on the course surface. The track surface must be in contact with the course when the snowmobile is under a full power run.
2. Any commercially available and properly filled OEM track is allowed. The track must be a track issued for the number of cc's of the motor. A 60cc variance is allowed, i.e., a 650cc engine must have a minimum of 600cc or greater rated OEM track.
3. Speed tracks and suspensions are allowed.

TRACK SUSPENSION

1. No carbon fiber slide rails allowed.

FRAME & BODY

1. Snowmobile must resemble a stock model and profile. Minimum handlebar height 30" inches from ground to center of tube.
2. Aftermarket body panels and approved duplications of production bodies of any material will be permitted if OEM appearance for the declared model and brand is maintained. The hood and belly pan may be removable. One-piece hood with side panels and or air dams molded in are allowed. Hood must have top and side cowling and must contain at least one thousand three hundred (1300) square inches. Front air dams allowed. Must be a minimum of 2 inches above the ground with front suspension fully compressed.
3. Windshields are required.
4. No additional bodywork that changes stock appearance allowed.
5. Ventilation openings may be covered.
6. Suspension side skirts are prohibited.
7. Aerodynamic devices, airfoils, and wings are prohibited.
8. Openings for component accessibility are allowed.
9. Cowl, or gas tank area must blend into seat.
10. Seats other than OEM stock, are allowed. Stock seats may be cut down for lower profile. All seats must be a minimum of 2" in thickness.
11. Commercially available aftermarket and custom frames are allowed. Design and structural integrity are subject to technical inspection for safety and compliance to general rules section.
12. All aftermarket and custom frame components except braces, brackets, and gussets must be manufactured

from 4130 chrome moly tubing and plate or 7075, 6061, aluminum plate.
Use of stock OEM bulkhead allowed, and reinforcement of same is allowed.

13. Stock tunnels may be used with any commercially available aftermarket or custom front end.
14. Motor mounts and jackshafts may be changed from original location.
15. Snowmobiles using production or aftermarket tunnels that measure less than 1/8" or .125 inch in thickness shall add additional sheet or sheets of metal to the tunnel to achieve .125 thickness. The sheet metal shall be the same width as the tunnel and shall extend from the rear of the tunnel to the horizontal centerline of the track drive axle. Tunnels 1/8-inch (.125) thick or thicker do not require this added sheet provided that the 1/8-inch (.125) tunnel extends to the horizontal centerline of the track drive axle.

IGNITION & ELECTRICAL

1. Any ignition may be used. Electrical stutter boxes launch control and traction control allowed.
2. External electric starters are legal.

CHAMPIONSHIP CLASSES

2024

OUTLAW

PRO EXTREME 55.

LIMITATIONS

One Power Adder allowed- Pro Extreme 55

Multiple Power Adders allowed.- Outlaw

Turbo 4-stroke - 55mm inducer

Turbo 2-stroke - 61mm inducer

Supercharged 4-stroke - 68mm inducer.

Nitrous 2/4-stroke - Unlimited

FUEL

1. Gasoline only

IGNITION & ELECTRICAL

1. Any ignition allowed.
2. Any instrumentation is allowed.
3. Wiring may be removed.
4. Headlight and taillight must be functional.

SUPER TWIN LAKE RACER

Except for the following rules, rules for this class are the same as Pro Extreme 55.

1. Super Twin is a stock appearing class.
2. Super Twin class sleds must weigh a minimum of 700 pounds.
3. Any stock or 0.500-inch speed track may be used.
4. Air dam allowed.
5. Fuel cell allowed.
6. Stock length skis must be used.
7. Any power adder allowed.

OPEN FUEL CLASS

GENERAL

1. There are two Open Fuel classes: Open Fuel I Maximum 1100cc Open Fuel II Maximum 4400cc. (See individual sections for details.)
2. Multiple engines are allowed in both classes. See engine rules for details.
3. All snowmobiles competing in open fuel must comply with GENERAL RULES AND REGULATIONS section.
4. There will be no movement into this class from a lower class.
5. A braking parachute is required, a recognized manufacturer must have produced it. Tech inspectors may observe the operation of the parachute and inspect for worn or frayed lines, ripped or dirty canopies and worn or ragged pilot chutes. Parachute cable housings must be mounted solidly to the frame or other suitable member; the use of quick pins for parachute mounting is prohibited. The parachute must be mounted in a manner that does not render it inoperative if the snowmobile should lose a track or part of the snowmobile (specifically, mounted above the snow flap and at the center of the rear of the tunnel). Particular attention must be paid to the mounting of the parachute, so it retains the integrity to remain centered on the chassis when deployed. (This is extremely important to retain control of the sled when deployed.) The parachute controls will be mounted so they are accessible to the participant in a normal driving position, handlebar control deployment required. **Must be electronic or pneumatic only. No mechanical linkages allowed.** Parachutes are to be repacked before each event, and not remain in the pack for extended periods of time. Refer to manufacturer's instructions for parachute use and packing.
6. On open cockpit snowmobiles, it is mandatory that a regulation parachute be mounted securely.
7. The maximum snowmobile width is 50 inches.
8. The minimum ski stance (spindle- to spindle is 30 inches. The participants torso must sit forward of the center of the rear axle.
9. Drivers must weigh a minimum of one hundred seventy-five (175) lbs., including protective gear. If the participant does not meet the minimum weight requirement, they must add ballast to the snowmobile.

ENGINE

1. The engine(s) must appear to be a snowmobile engine.
2. The engine and engine components shall have been manufactured for snowmobile use, unless otherwise specified by the class rules (Outboard, motorcycle, aircraft, ATV, watercraft or automotive engines and engine components are not allowed). The Race Rules Committee will approve the validity of all engines.
3. Any snowmobile crankcase, crankshaft, cylinders, and heads are allowed.
4. Gasoline and/or alcohol may be used as fuel.
5. Any fuel injection is allowed.
6. Any functionally silenced exhaust allowed. Exhaust emission pipe must not protrude more than three (3) inches beyond the chassis or hood configuration.

DRIVE

1. No holes may be drilled in the protective shields.
2. The track(s) must be driven by a single drive axle.
3. All snowmobiles must be equipped with an adequate hydraulic brake system on the final drive axle.
4. All snowmobiles 800 cc's and above must have a twin opposed piston caliper braking system with a minimum 3/16 inch thick, six (6) inch minimum diameter brake disc. Any manufactured brake disc may be milled or drilled in the original pad contact area (all pads inclusive). The disc pad contact surface area must not be reduced more than fifteen (15%) percent of the original pad contact surface area.
5. No carbon fiber drive wheels or non-driving wheels allowed.

SKIS & SKI RUNNERS

1. Ski must be a minimum of 3/4 inch wide, three (3) inch diameter loop, four (4) inch height and a minimum length of twelve (12) inches. Skis confined within the hood are exempt from the height rule.

TRACK & TRACTION

1. The continuous track length is to run parallel to the snowmobile length and maintain 20 inches in length of continuous surface traction on the course surface. Track surface must be in contact with the course surface when the snowmobile is under full power.
2. Minimum total track(s) width is 11 1/4 inches. Maximum total track width is 16 inches. A 1/8-inch variance per track in the minimum track width requirement is allowed.
3. **Any new track or track system must be approved by ISR Rules Committee.**

TRACK SUSPENSION

1. No carbon fiber slide rails allowed.

FRAME & BODY

1. A 1/8-inch 6061T6 aluminum sheet of metal shall run the width and length of the tunnel down over the front of the tunnel to the center line of the drive sprocket.
2. Seat must have a minimum of four (4) inches rigid backrest on seat.
3. All fuel tanks must have a pressure cap and be vented to the outside of the body or have a built-in check valve. Fuel lines must be free of obstruction by other snowmobile components.

IGNITION & ELECTRICAL

1. Any ignition allowed.
2. An additional shut-off shall be located at the rear of the snowmobile to close off all electrical fuel systems and be clearly marked (see GENERAL RULES AND REGULATIONS SECTION).

2024 NITRO Event Fire Safety Requirements

Rider Safety Requirements

1. Full coverage all-leather suit or SFI SPEC 40.1/2 full coverage suit. **SFI Foundation**
2. Suits may be one-piece design or two-piece design that is joined with a zipper, at the waist.
3. Leather boots that completely cover the ankle with toe-area reinforcement.
4. Full-finger leather gloves are mandatory. Gloves must be Kevlar-lined or equipped with slider buttons and must have knuckle armor and palm reinforcement.
5. No exposed skin other than the eye port(s) in the head sock.
6. Single Layer Nomex Balaclava Helmet Head Sock / SFI SPEC 3.3 **SFI Foundation**
7. **Full Face Snell SA2020 Helmet w/Nomex interior and full coverage. A list of certified helmets can be found here <https://smf.org/cert>**

Nitro Snowmobile Requirements

1. All Supercharged and Turbocharged Nitromethane entries, using ANY percentage of nitromethane, must utilize a SFI SPEC 23.1 Burst panel. Burst panel must be located between the supercharger outlet/discharge and the intake valve.
[SFI Foundation](#) / [Burst Panels \(goodvibesracing.com\)](#)
2. All Screw Charger units and Roots supercharger units must utilize a SFI SPEC 14.2 restraint system OR the units must integrate into the chassis.
3. Contact STROUD Safety products@stroudsafety.com
4. SFI Ballistic blankets are mandatory on ALL Nitro Screw Charger, Nitro Roots Blower, Nitro Pro Charger, and Nitro Turbo entries, regardless of the percentage of Nitromethane.
5. Contact STROUD Safety products@stroudsafety.com
6. V-Twin Nitro entries require a SFI SPEC 46.1 engine restraint system Contact STROUD Safety
7. For ALL electronic and mechanical fuel injection entries, all ignition ON/OFF and kill switches (including the tether kill switch) must also shut of the fuel.
8. Mechanical or pneumatic fuel shut off required.
9. Nitromethane is not allowed on any carbureted engines.

Event Fire Safety Requirements

Fire Extinguishers Required. Starting Line: Qty-2 / UL 4A:80B:C Fire extinguishers

Finish Line (500ft): Qty-2 / UL 4A:80B:C Fire extinguishers

Shutdown (1000ft area): Safety vehicle (UTV w/tracks) will be equipped with a MINIMUM of Qty-2 / UL 4A:80B:C Fire extinguishers.

TECHNICAL DATA

Fuel Information

	VP C14	VP METH	VP NITRO
DOT Transport Hazard class	3	3	3
GHS Flammability	2	2	3
Flash Point	-40F	44.5F	95F

Under GHS, all liquids with a flash point of not more than 199.4°F (93°C) are categorized as flammable liquids. Flammable liquids are further subdivided into categories:

1. Category 1 liquids have flash points below 73.4°F (23°C) and boiling points at or below 95°F (35°C).
2. Category 2 liquids have flashpoints below 73.4°F (23°C) and boiling points above 95°F (35°C).
3. Category 3 liquids have flashpoints at or above 73.4°F (23°C) and at or below 140°F (60°C). When Category 3 liquids with flash points at or above 100°F (37.8°C) are heated for use to within 30°F (16.7°C) of their flash point, they must be handled in accordance with the requirements for a Category 3 liquid with a flashpoint below 100°F (37.8°C).
4. Category 4 liquids have flash points above 140°F (60°C) and at or below 199.4°F (93°C). When Category 4 flammable liquids are heated for use to within 30°F (16.7°C) of their flash points, they must be handled in accordance with the requirements for a Category 3 liquid with a flashpoint at or above 100°F (37.8°C).
5. In addition, the new rules specify that when a liquid with a flash point greater than 199.4°F (93°C) is heated for use to within 30°F (16.7°C) of its flash point, it must be handled in accordance with the requirements for a Category 4 flammable liquid.

PRO EXTREME 55

Pro Extreme 55 is a class designed to allow competition between extremely high horsepower sleds in various chassis designs.

ICE course only, competition always will be limited to two sleds at one time, with a minimum of one lane separation between the sleds. Ice course shutdown (run off) must be a minimum of 2000 feet.

All rules for this class are subject to change at any time and without any grace period.

PRO EXTREME 55
 Turbo / Supercharged - 750 lbs.
 Nitrous – 650 lbs.
 N/A under 1050- 550 lbs.
 N/A over 1050 600 lbs.
 LIMITATIONS SINGLE POWER ADDER ONLY.
 Turbo 4-stroke - 55mm inducer
 Turbo 2-stroke - 61mm inducer
 Supercharged 4-stroke - 68mm inducer.
 Nitrous 2/4-stroke – Unlimited

GENERAL SNOWMOBILE REQUIREMENTS

1. All snowmobiles competing in the Pro Extreme 55 class must comply with GENERAL RULES AND REGULATIONS SECTION.
2. Race Director shall have the authority to determine structural integrity.
3. Competition is open to any snowmobile, either production or one of a kind, experimental units, (which could include rear engine type units)
4. Maximum overall length is 144 inches.

ENGINE

1. The engine must be from a stock -qualified snowmobile. The rules committee will approve the validity of all engines. Two cycle watercraft crankcase and crankshaft from a snowmobile manufacturer may be used. Internal and external modifications are allowed. (Clarification 4/24/22)
2. There is a 2000 maximum c.c. limit on total engine volume.
3. One power adder, allowed. Supercharging, turbo charging, or nitrous oxide systems are allowed, but may not be combined. Example, if a competitor adds a turbocharger to an engine, he may not also add a nitrous system.
4. Fuel injection systems are allowed.
5. Turbo Exhaust must be constructed in a manner that the exhaust outlet is not directed at the driver or competitor.
6. Maximum turbo inducer size is 55mm.
7. Exhaust system must fit within overall maximum length and width rules.
8. This is a gasoline only class, VP Import, VP Q16 are the only oxygenated fuels allowed.

DRIVE

1. Any CVT type primary and secondary clutch may be used.
2. Primary clutch and secondary clutch may be modified (no RPM limit)
3. Clutch cover must have full facial coverage and 360-degree elliptical coverage in the direction of clutch/belt travel (see illustration). Clutch cover must be .090-inch 6061T6 aluminum or equivalent steel material and be covered with six (6) inch belting. Other clutch cover materials not allowed. If the clutch cover is fastened to the existing belly pan, the area below the clutches (from front of cover to rear of cover and width of cover) must be covered with .090-inch 6061T6 aluminum or equivalent. If cover is .125 inch, 6061T6 aluminum or equivalent steel material, belting is recommended, but not mandatory. Clutch cover and related belting must be securely fastened.

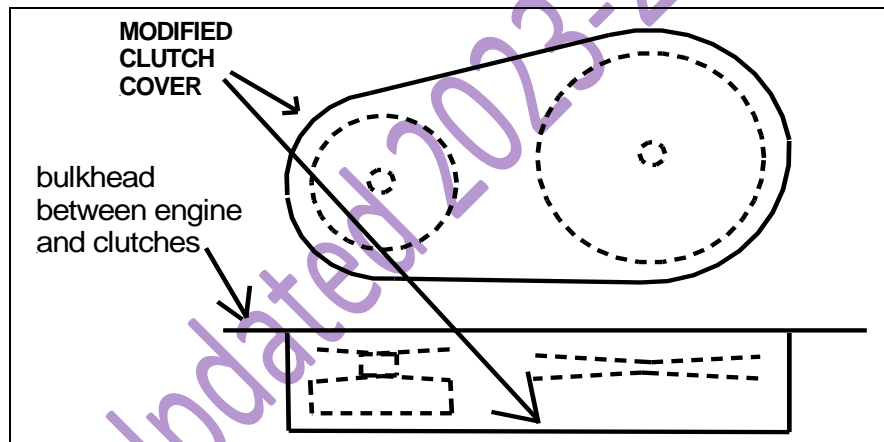

1. Backside of clutches must be covered by a portion of the clutch cover or by a bulkhead of comparable material.
2. Custom clutch guards, clutch guards on purpose-built chassis, and specialty chassis may use Carbon fiber, Kevlar, and other materials as reinforcement of standard clutch guard material and design. Newly designed clutch guards must exceed the specifications and limits established in standard clutch guard requirements. See specific disciplines for details. Each specific clutch guard must be submitted to ISR with digital pictures (both installed and uninstalled, at least four views) and a detailed explanation of design, design limitations, and method and type of fasteners used to affix the guard to the chassis. ISR may request an appointment to inspect on site.
5. Pro Extreme 55 class sleds must have a twin opposed piston caliper braking system with a minimum 3/16 (.015-inch tolerance) inch thick, 6.0-inch minimum diameter brake disc, mounted on the drive axle. Any manufactured brake disc allowed, except no aluminum brake disc may be used.

SKI SUSPENSION AND STEERING

1. The front suspension must remain OEM design concept but may be changed in shape and appearance.
2. Material substitution is allowed. Replaced components acceptability for construction and strength will be at the discretion of the Technical Inspector. Inspection holes may be required to be bored into components at any time by Technical Inspectors. Technical Inspectors decision regarding acceptability is final. New, novel, or controversial designs are strongly suggested to be presented to technical approval, during the construction process for review. Construction concepts will remain proprietary to the builder but may be forwarded to select SMDG members with expertise in the area for advisory input.

SKIS & SKI RUNNERS

1. Any commercially available OEM appearing, or aftermarket ski may be used provided the original spring concept remains the same.
2. Minimum ski length is ~~twenty(20)~~ 17.5 inches.

TRACK SUSPENSION

1. Must be a minimum of 2 inches of remaining compression travel with driver on snowmobile. Functional suspension required.

TRACK & TRACTION

1. Any commercially available one-piece molded rubber track allowed. Track must be race designated by the molder of the track. No cleated tracks allowed. Track must be race designated by the molder of the track or the modifier of the track. Or/part numbers given to ISR from the track modifiers. (Tracks USA, Hyper sports, and others.) 159inch maximum length for all classes unless specified. Reviewed end of 2023 season for Pro Extreme 55.
2. Speed tracks and suspensions will be allowed.
3. Track lug height may be trimmed to a minimum of ½ inch lug height. No other track trimming allowed.
4. Minimum track width is ~~13.5 inches~~. 10.5 inches
5. Any traction device must not extend more than ¾ inch, (.750 inch) above the highest point of the track or traction lug.

FRAME & BODY

1. Snowmobile must resemble a stock model and profile. Minimum handlebar height 30" inches from ground to center of tube.
 2. Aftermarket body panels and approved duplications of production bodies of any material will be permitted if OEM appearance for the declared model and brand is maintained. The hood and belly pan may be removable. One-piece hood with side panels and or air dams molded in are allowed. Hood must have top and side cowling and must contain at least one thousand three hundred (1300) square inches.
 3. Front air dams allowed. Must be a minimum of 2 inches above the ground with front suspension fully compressed.
 4. Windshields are required.
 5. No additional bodywork that changes stock appearance allowed.
 6. Ventilation openings may be covered.
 7. Suspension side skirts are prohibited.
 8. Aerodynamic devices, airfoils, and wings are prohibited.
 9. Openings for component accessibility are allowed.
 10. Cowl, or gas tank area must blend into seat
 11. Seats other than OEM stock, are allowed. Stock seats may be cut down for lower profile. All seats must be a minimum of 2" in thickness.
 12. Commercially available aftermarket and custom frames are allowed. Design and structural integrity are subject to technical inspection for safety and compliance to general rules section.
 13. All aftermarket and custom frame components except braces, brackets, and gussets must be manufactured from 4130 chrome moly tubing and plate or 7075, 6061, aluminum plate. Use of stock OEM bulkhead allowed, and reinforcement of same is allowed.
 14. Stock tunnels may be used with any commercially available aftermarket or custom front end.
 15. Motor mounts and jackshafts may be changed from original location.
 16. Snowmobiles using production or aftermarket tunnels that measure less than 1/8" or .125 inch in thickness shall have the one of the following:
 - A. Additional sheet or sheets of metal to the tunnel to achieve .125 thickness. The sheet metal shall be the same width as the tunnel and shall extend from the rear of the tunnel to the horizontal centerline of the track drive axle. Tunnels 1/8-inch (.125) thick or thicker do not require this added sheet provided that the 1/8-inch (.125) tunnel extends to the horizontal centerline of the track drive axle.
- OR
- B. Two (2) tunnel protectors permanently fastened to the inside of the tunnel. Tunnel protectors must be minimum 1.500 inch tall (height) and may be either rectangular aluminum tube or machined aluminum. The tunnel protectors shall extend from the rear of the tunnel to the horizontal centerline of the track drive axle.
- Tunnels that are 1/8-inch (.125) thick or thicker do not require additional protection.

IGNITION & ELECTRICAL

1. Any ignition may be used. Electrical stutter boxes launch control and traction control allowed.
2. External electric starters are legal.

OPEN FUEL RULES**GENERAL**

1. The minimum length is seventy-two (72) inches, with the minimum length of the front spindle center to the center of the rear axle to be

sixty-seven (67) inches.

2. The minimum wet weight (without gas) is 330 lbs.
3. Drivers must wear a one-piece leather suit (or a two-piece suit must be securely fastened together at the waist), leather gloves, and leather boots that extend 6 inches above the ankle.
4. Drivers must wear a fire protection sock over their head and neck, inside their helmet.
5. All rear engine snowmobiles must be equipped with a regulation roll cage.

ENGINE

1. A maximum of 1100cc's (all engines combined) with a .020 inch (1/2mm) overbore is allowed.
2. Pressure charging and nitrous oxide are allowed as follows:
 - a. 600cc may use turbochargers, superchargers and/or nitrous oxide.
 - b. 800cc may use turbochargers, superchargers, or nitrous oxide.
 - c. 1100cc may use nitrous oxide only. No other pressure charging allowed.

DRIVE

1. The snowmobile must be propelled by a variable ratio belt transmission.
2. A maximum of one (1) snowmobile clutch is allowed.
3. The chain must be completely enclosed. A maximum of two (2) lubrication holes (3/4- inch diameter) each may be drilled in the approximate location of the sprockets on the outboard side of the case.
4. No carbon fiber drive wheels or non-driving wheels allowed.

FOUR STROKE TURBO

NSSR 2023 FOUR STROKE CLASSES with TURBO *(Jan 2022)*

SNOWMOBILE RULES FOR COMPETITION

1000 FOOT SPEED RUN

All Competitors will run OEM four stroke engines that are produced with a factory turbo or modified to add a turbo. Aftermarket engines are allowed only per ISR rules. The intent of the stock and improved stock four stroke classes is to make this a fair class with ease of providing tech and with the understanding that any slight modification to the ECU can improve performance immensely or access to special tuning programs by the factory can alter performance also. All ISR apply to these classes, unless noted differently on this list of items.

Tether required for competition. Safe Jac required as per all stock classes. Leather suits are required for speeds at or exceeding 135mph and otherwise noted.

Stock Turbo Four Stroke:

Stock bodywork, skis, seat, and suspension required to be OEM for model and year. In addition, headlight and taillight shall be maintained and in working order. A windshield is required and must be a factory or aftermarket for the model, with low profile allowed as a replacement.

Shocks in the front suspension and rear suspension may be modified or replaced to allow lowering of the snowmobile to meet minimum clearance of 2 inches on the Belly pan.

Rear Suspension shall maintain 2 inches of travel. Slide lube system is allowed per stock rules.

Track may be a 0.5-inch lug competition track as approved by ISR and ice picks required to be at 50% and not over 1 inch above the top of the track lug. Plastic drivers may be replaced or modified to facilitate the 2.52 drive system and extrovert lugs removed for competition.

Weight with Driver and Snowmobile will maintain 825 lbs. for 998/1050 cc motors and 775lbs for the 900 cc motors after the run is completed.

Snowmobile will maintain stock engine and muffler, along with stock clutches. Aftermarket clutch parts and gears may be exchanged for like parts. Belt adjuster may be added.

Stock ECU may be reprogrammed per manufacturer or aftermarket but must remain as sold stock from dealer in location and connection.

Reverse gears and assembly must remain intact. Headlight and taillight will remain functional. No Oxygenated fuel allowed.

Improved Stock-Stock Turbo Four Stroke

All stock rules apply unless noted below:

All Stock Turbo rules apply and may be modified as noted for Improved Stock competition.

A surge tank may be installed for fuel, but the stock tank must be maintained. No Oxygenated fuel or Methanol allowed. Fuel will be evaluated upon completion of a run of good standing or at the discretion of the race or tech director. Injectors and/or fuel pump may be replaced.

The Engine will remain in Stock Production including the head and valve assembly.

Stock turbo required and must remain in stock position as OEM. No modification allowed.

Aftermarket Air Filter is allowed along with the replacement of the muffler and must exit the stock location as production.

If not equipped with an O2 sensor, it may be added.

Reverse gears/assembly in chain case may be left in or removed and substituted as desired.

Stock ignition and fuel system must be maintained, but the stock ECU may be modified by aftermarket or factory programming, along with the installation of an Aftermarket ECU may be installed to allow for the reprogramming before, during, or after the Race Event. All aftermarket ECU's must fit or have an adapter to leave the in-place wiring harness and connectors per OEM.

Weights for competition will be as per Stock above.

Pro Stock-Stock Turbo Four Stroke:

Rules are per ISR for this competition class.

Overall, this is a stock chassis class with modifications allowed to stock body parts, seat, aftermarket suspension, drive axle, rear tunnel, lightweight front end all to resemble stock form. Belly pan to remain intact. Tracks for this class will be stock width available tracks per ISR.

Hence, we are only allowing a 0.5-inch lug track that meets ISR rules and may not be cut down.(13.5-inch track is minimum width)

Engine may be modified with aftermarket internals, including the cams and valves. The stock crankcase and head must remain intact.

No Oxygenated Fuels.

Weights will be 750 lbs. for the 3 cyl 998cc and up, 710 lbs. for the 2 cyl 1050 cc, 685 for the 3 cyl 900 cc.

Aftermarket chassis or stock chassis that is reinforced substantially in the tunnel or bulkhead to represent an aftermarket production will not be allowed to run in this class. They will compete in the Pro Mod Class if available for competition, or in a higher-class level.

Leather Suit mandatory in this class.

Pro Mod – Stock Turbo Four Stroke

Rules are per ISR for this competition Class.

Class does allow aftermarket chassis and the use of Oxygenated Fuels. Aftermarket and one-piece hood assemblies allowed for body work.

Track width will remain no less than 13.5 inches and with a 0.5-inch lug.

Weights will be 750 lbs. for the 3 cyl 998cc and up, 710 lbs. for the 2 cyl 1050 cc, 685 for the 3 cyl 900 cc.

Parachutes recommended for speeds of 150 mph or above and mandatory at 160 mph.

Leather Suit is mandatory in this class. **Ski loops not required in full body over steering designs.**

Pro Extreme 55 – Four Stroke

Rules and weight per ISR. Fuel per ISR. Four Stroke Turbo weight is at 750 lbs.

NSSR will allow a minimum track width of 10.5 inches and track to be narrowed by approved method of water jetting or vendor such as Tracks USA.

Leather Suit and functioning parachute mandatory in this class. **Ski loops not required in full body over steering designs.**

Pro Stock – Open Turbo – Four Stroke

Rules per ISR. Fuel per ISR. Minimum Weight of sled and driver is 700 lbs.

NSSR will allow a minimum track width of 10.5 inches and track to be narrowed by approved method of water jetting or vendor such as Tracks USA.

Leather Suit and functioning parachute mandatory in this class. **Ski loops not required in full body over steering designs.**